

COMPLEXITY IN STRUCTURED FINANCE AND DIFFICULTIES FACED BY MARKET PARTICIPANTS-A CRITICAL ASSESSMENT OF THE ROLE OF THE COMPLEXITY IN FINANCIAL CRISIS



Nafiz Ul Fahad^{1*}
Mehnaz Roushan
Laura²

¹Lecturer, School of Business, Independent University Bangladesh (IUB), Dhaka, Bangladesh

²Lecturer, Department of Accounting and Information Systems, Faculty of Business Studies, Jahangirnagar University, Dhaka, Bangladesh



(+ Corresponding author)

ABSTRACT

Article History

Received: 15 May 2017

Revised: 14 June 2017

Accepted: 29 June 2017

Published: 25 July 2017

Keywords

Structured finance
Financial complexity
Financial crisis
Credit rating agency
Investment bank
Securitization

JEL Classifications

G21, G24, G28, F650, G180

The global financial crisis has been blamed on the part of the increasing complexity in the financial system which is one of the key developments in modern finance. Due to greater globalization and the integration of financial institutions and markets, they have become more interconnected and more fragile in the financial system. A significant proportion of the complex nature of the financial system results from the development of complex structured finance securities. The aim of this study is to investigate the remarkable rise and fall of structured finance by emphasizing the role of complexity. This study first examines the ways in which structured finance become more complicated over the last two decades. Complexity in structured finance arises from the pooling of assets, the detailed deal-specific structuring and documentations necessitated by tranching and the involvement of third parties. Besides, we have defined the term 'complexity' more narrowly to provide a better understanding of the essence of the complexity. Further, this study examines the motive for the financial institutions to issue more complex structured finance securities and finds that the increased complexity has been used as a mechanism to distract market participants. Finally, the complex structure of securities along with the perverse incentives and gluttonous behaviour of the market participants have undoubtedly impelled financial market towards more complex condition and ultimately thrust towards the collapse.

Contribution/ Originality: This is the very first study that vastly documents the role of complexity in financial crisis. This study not only examines the complex structure of the structured finance products but also address the voracious behavior of the market participants which has compelled financial system toward more intricate situation.

1. INTRODUCTION

In the study of Brunnermeier and Oehmke (2009) it is noted that the core of the global financial crisis is caused by a particular class of complex structured finance securities such as ABS, MBS, CDOs, CDOs squared and other kinds of derivative instruments. The essence of structured finance denotes the process of designing financial products through pooling economic assets (e.g., bonds, loans, mortgages) to produce prioritized capital structure claims (known as tranches) where these securities are backed by collateral pools. Due to the ability of structured

finance to repackage risks and the use of prioritization scheme in the structured claim, most of these assets were viewed virtually risk-free by investors and certified as such by the credit rating agencies (CRAs). However, the sudden breakthrough of the global financial crisis in 2007-2008 has revealed that these securities were far more complex and riskier than they were initially predicted. In response to this financial turmoil, many critics have argued that securitization and complex structured finance products may have made the financial system more complicated. This raises the question whether the complexity of these financial securities was the crucial determinants for the development and propagation of the financial crisis. Given the rise of delinquencies in structured finance and the substantial fall in the use of securitization¹, the focus has now placed on the mechanics of these structured securities (Furfine, 2014). Much of prior academic literature have concentrated on the issue related to the problems arising among the market participants of the securitization process- creator of the loans, the underwriters, CRAs and the investors of those securities. However, various influential studies from Judge (2012); Awrey (2012) and Ghent *et al.* (2014) argue that complexity did play a critical role in the duration and severity of the global financial crisis. This study contributes to the existing literature by focusing on three main aspects that are dominant factors in the debate of structured finance's complexity. To our knowledge, no finance scholars have exceedingly investigated the role of complexity in financial crisis to date. First, we have attempted to investigate why these structured finance securities are getting more complicated. To answer that question, we have started by scrutinizing the architecture of the structured finance and how it works. For better understanding, we have used prototypical structured finance security- collateralized debt obligation (CDO) as an example to show how complexity can arise from the pooling and tranching process. Further, we have attempted to define the complexity more narrowly since it is hard to obtain a workable definition. Second, we have explored what drives financial institutions to develop more complex securities and how complexity can be used as a means to distraction. To provide perspective, we have examined the emergence of structured finance markets from the standpoint of supply-side and demand-side incentives. Third, we have attempted to look at how the market participants can further exacerbate the complexity in the structured finance market. To provide better assessment, we have tried to explore the reasons behind the perverse incentives and suspect behaviour on the part of issuers, underwriter and rating agencies.

The rest of the article is organized as follow: next section gives an overview of the background and historical development of the complex structured finance. Section 3 pays attention to providing an overview of the mechanism of structured finance and its' key market participants. Section 4 covers main arguments regarding the 'complexity' as an important determinant in modern finance. The fifth and final section summaries and concludes.

2. BACKGROUND AND HISTORICAL DEVELOPMENT OF COMPLEX STRUCTURED FINANCE SECURITIES

The first securitization process began in the United States (U.S.) in the early 1970s. This process involved the use of pools of mortgage loans and its rapid development was facilitated by the government-sponsored enterprise (GSE)². Over the course of the 1980s, Fannie Mae, Freddie Mac and Ginnie Mae began to arrange pass-through securities³ and a market appeared for consumer ABS in the U.S., whereby investors could buy and hold a pro-rated share of a pool of mortgages (Foote *et al.*, 2012). To manufacture a pass-through MBS, multifarious mortgages were

¹The term 'securitization' is strongly interrelated with the structured finance. Thus, structured finance can, in fact, be as a whole strongly identified with securitization technology Fabozzi and Kothari (2007).

²Such as Federal National Mortgage Association (Fannie Mae), Government National Mortgage Association (Ginnie Mae) and the Federal Home Loan Mortgage Corporation (Freddie Mac).

³Fannie Mae, Freddie Mac and Ginnie Mae issued their first "pass-through" MBS in which securities were 'passed-through' to investors once management fees and guarantee fees had paid to intermediary.

pooled and fractional claims were issued to satisfy investors with various appetites for risk. Regarding securitization structure, these processes were relatively straightforward as the guarantee of GSE eliminated the need for an investor to evaluate the credit risk. However, private-label MBS had also extended at that time, but only started to flourish after the middle of the 1980s due to several reasons. Fall of predominant 'originate-to-hold'⁴ banking model and the abolition of the existing state laws in buying these private securities, had played key roles on this proliferation (Beyer and Bräutigam, 2013). In 1983, Fannie Mae and Freddie Mac issued the first structured securitization called collateralized mortgage obligation (CMO). CMO allowed GSE to sell an array of complex securities with different repayment properties (principal-only, interest-only, floating-rate notes, fixed-rate notes and so on) secured by a pool of mortgages (Foote *et al.*, 2012; Beyer and Bräutigam, 2013). However, a financial structure called Real Estate Mortgage Investment Conduit (REMIC) was created based on the 1986 Tax Reform Act⁵, which permitted sellers to produce complex MBSs without the help of the government-sponsored enterprises. Prior to this Act, the creation of these complex mortgage deals had been difficult without GSE's involvement. During the mid-1990s, the origination and securitization of subprime mortgage started to come into sight in the U.S. with the changes in the design of mortgage contracts. Due to the advantage of GSE in the securitization of conforming loans, the share of MBSs backed by subprime loans had increased significantly over the period of 1996 to 2006. Unlike the prime mortgage⁶ market, independent lenders could make subprime lending without federal supervision, which involved adjustable rate or low 'teaser rate' for the first few years and then subsequently adjust to a higher rate. Thus, subprime lending was an alternative approach for troubled borrowers to have unsecured credit (Foote *et al.*, 2012). In the course of the dynamic evolution of structured finance, the arrival of collateral debt obligations (CDOs) was the next step in the securitization of debt. The CDO first appeared at the end of the 1980s as a way for banks to sell the risk on pools of commercial loans known as collateralize loan obligations (CLO). Over the time, financial institutions discovered that pools of risky tranches from securities including private-label securities backed by a mortgage could also be used to construct CDO structure. In 2000, investment banks started to use this group of innovation technique by mixing lower-rated tranches of mortgage securities, typically subprime asset-backed securities with other forms of securitized debt to construct CDOs. This led to the creation of ABS CDO. Further, (Schwarcz, 2008) indicates that ABS CDO transactions are sometimes also referred to as 're-securitization' as these securities are backed by a mixed pool of ABS or MBS securities. However, the construction of CDO by comprising other securitized assets was not the end of story. In fact, financial intermediaries continued to involve in the resecuritization process in which they used ABS CDO tranches to construct CDO squared and even the CDO cubed. The principal motivation behind these transactions was to create value by transforming lower rated securities into higher-rated ones which were the same as that underlying creation of CDOs (Judge, 2012). Theoretically speaking, this process of resecuritization has no limit. Thus, this complex process enables large banks to create and sell any pool of loans, securities or revenues into any form of structured products. Another major innovation in the area of structured finance was the development of hybrid and synthetic CDOs. Synthetic CDOs are backed by a pool of credit default swaps (CDS) referencing MBSs or other assets in which Special purpose vehicles (SPV) does not obtain the underlying debt instruments. Here, SPV is used as a means of securitization process for property-based financial products. In the process of securitization, the sponsor or originator creates the

⁴Originate-to-hold' banking model involves making loans with the intention to hold them through maturity. For further discussion, see <http://www.nasdaq.com/investing/glossary/o/originate-to-hold>

⁵The 1986 Tax Reform Act had passed by U.S. Congress to simplify the income tax code, extend the tax base and abolished many tax shelters. Further it also allowed mortgage securities to be issued in the form of REMIC which passes certain tax advantages to both issuers and investors. For further discussion, see <http://www.ctj.org/html/taxvotes.htm>.

⁶Prime mortgage was a long-term fixed-rate mortgage made under tight federal supervision.

SPV as a legal entity by transferring assets to carry out some circumscribed activities or series of such activities. CDS is a 'pure' credit derivative instrument in which seller of a CDS agrees to pay buyer if a credit default event of a reference asset occurs and in exchange the credit protection buyer pays a fee, usually called a 'premium.' A related product, the hybrid CDO is backed by a combination of cash producing assets and CDS. Prior to the financial crisis, markets for the structured finance securities had encountered massive growth in the U.S. and Europe, as it had grown from \$500 billion in 2000 to \$2.6 trillion until July 2007 (World Economic and Financial Surveys, 2008). Furthermore, while the issuance of CDOs has grown from \$150 billion in 2000 to \$1.2 trillion in 2007, CDS issues have reached to the record-breaking volumes of \$18 trillion in mid-2007 from \$1 trillion in 2004 (WEFS, 2008). Further, credit rating agencies (CRAs) have also played a pivotal role in the development of the complex structured finance market over three decades. These ratings are crucial for market participants to make a better judgement regarding the creditworthiness of financial instruments. On the study of Coval *et al.* (2009) argue that the market for structured finance securities had developed as 'rated' market in which CRAs estimated the risk of tranches. The awoken of the financial crisis in 2007-2008 further revealed the error in cash flow projections of the structured products as it caused not only low-grade-rated tranches of ABS CDO securities to fall but also AAA-rated tranches of ABS CDO securities to be downgraded. By the end of 2008, when everything had changed, the primary question was why these complex tranches of structured finance obligations were radically over-rated by securitizers, CRAs, and issuers. Further, CRAs were highly criticized for their critical role in the evaluation of the complex structured securities as well as for their slow reaction to capture deteriorating credit risk of these securities. The error of CRAs may have depended on a number of reasons in which complexity has undoubtedly played a crucial role.

3. STRUCTURED FINANCE AND ITS MECHANISM

Structured finance relates to a group of complex financial instruments and mechanisms which can be defined through three distinct characteristics: (1) pooling of assets (2) tranching of liabilities backed by the asset pool and (3) credit risk of the collateral asset pool is separated from the credit risk of the originator through the involvement of SPV. The prime motivation behind the tranching of liabilities is to create one or more classes of securities with higher credit ratings by combining various asset classes to achieve greater transformation and diversification of risk. Thus, broadly speaking structured finance could be described as an alternative to direct investments in financial assets, as a mean to mitigate risk exposure of a portfolio, or as a way of exploiting market trends (Fabozzi *et al.*, 2006). Each of the three major features of structured finance provides the issuers great flexibility regarding security design, asset types and maturity structure as pointed out by Bavoso (2013). Due to the 'value-creation' ability of structured finance, it also attracts a range of market participants (Figure-1 represents the generic structured finance transaction along with major market participants).

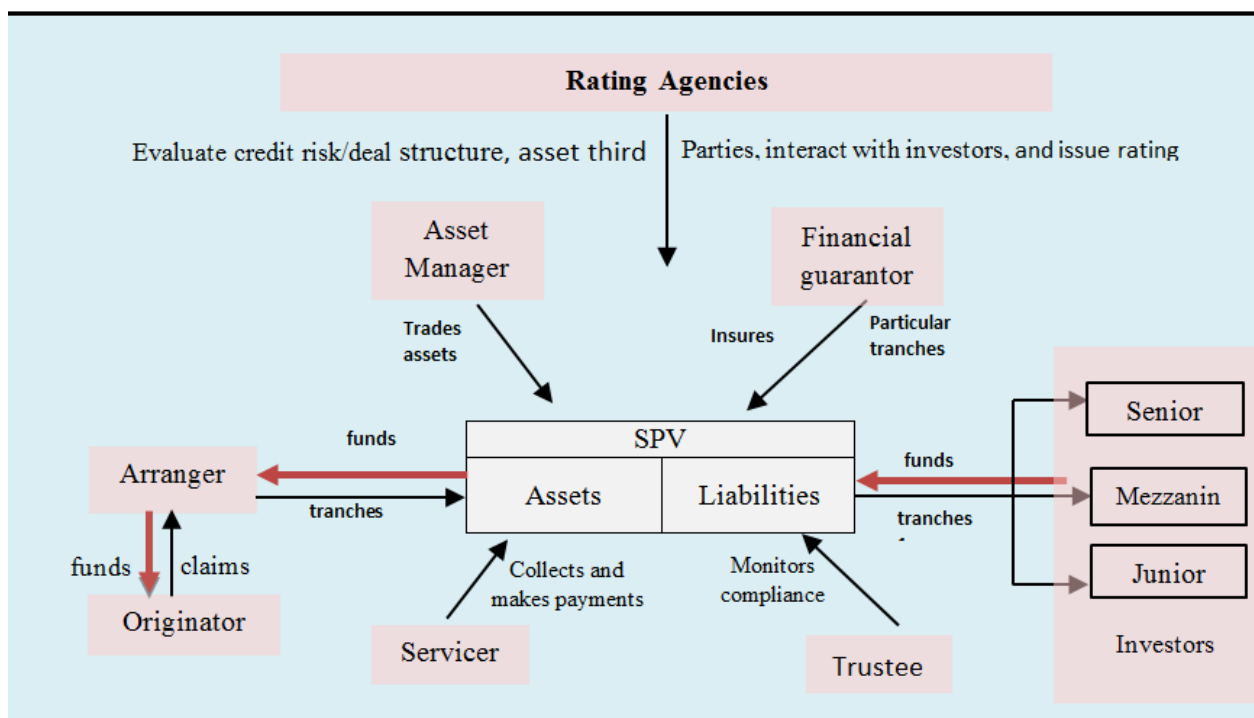

Figure-1. Overview of structured finance mechanism and the role of key market participants.

Source: Fender and Mitchell (2005)

The fundamental structure of a structured finance in securitization process involved a way to provide finance by transforming a loan into tradable bond and therefore into a transaction that utilizes SPV. To accomplish this, the originator (companies engaging in the origination of the financial assets) sells financial assets to an SPV in return for the purchase price of the financial assets where SPV issues securities to capital market investors. The SPV acts as an independent entity for the purpose of the transaction, even though the originating company sponsors it. Securities that are owned by the SPV can be classified customarily as MBS, ABS, CDO and ABS CDO. If the payment of the securities is backed by and derived entirely from mortgage loans, then it is called MBS. To the contrary, payment of the securities that stems from the other financial assets is called ABS. In the case of CDO securities, payment is obtained from the mixed pool of mortgage loans.

To produce rated securities from a pool of unrated assets, SPV further re-divided these assets into the three-tier category: senior (AAA), mezzanine (BBB) and unrated junior tranche. During the occasion of defaults, unrated junior tranche will consume the initial losses up to the degree where it is exhausted. Subsequently, mezzanine tranche will absorb the additional losses until it is depleted and followed by the senior tranche. Because of the priority ordering of payments, senior tranche has the first claim on cash flow. Within the structured finance transactions in figure 1, these securities are often guaranteed by third party credit enhancement mechanism to SPV, such as insurers or financial guarantor that has expertise in securitization known as ‘Monoline’ insurers.

⁷The insurers are called ‘Monoline’ insurer because their business is concentrated on single line insurance and they are the only entities allowed to provide financial guarantees under New York law. For further discussion, see Tavakoli (2008).

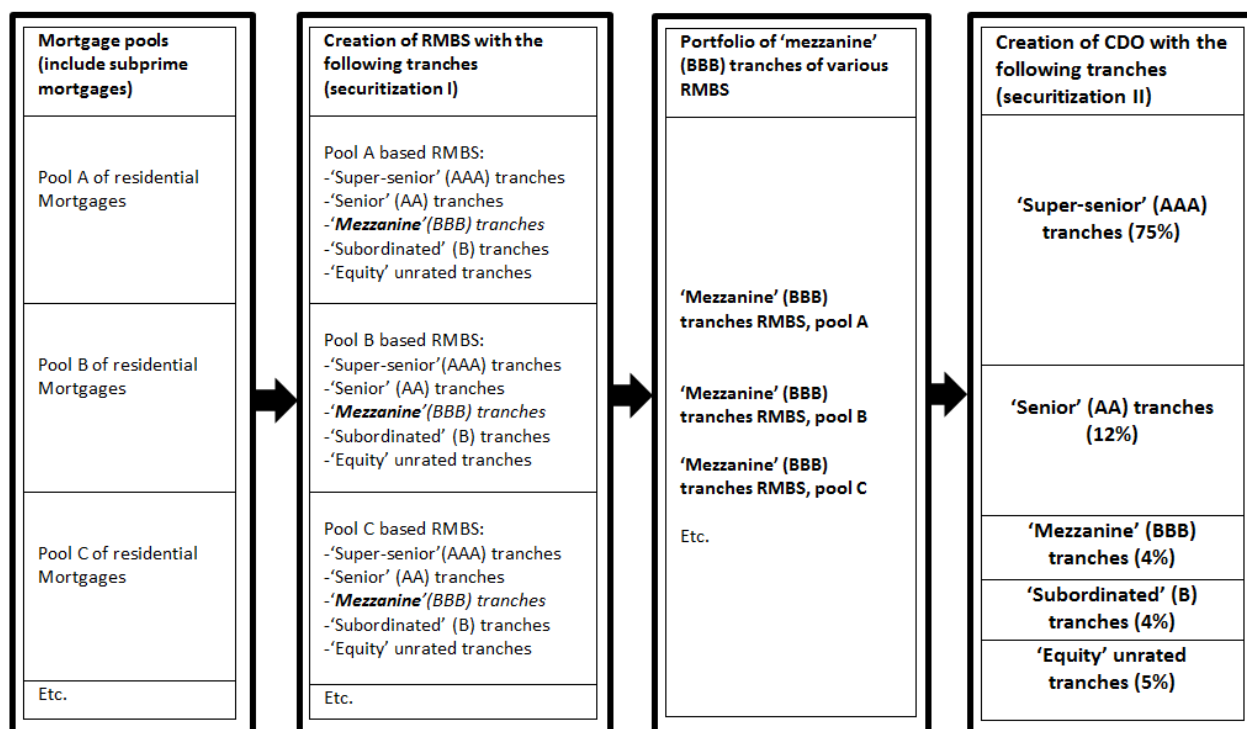

Figure-2. The process of manufacturing AAA-rated securities out of subprime mortgage

Source: Criado and Rixtel (2008).

Securities issued by the SPV are then rated by CRAs to provide reliable judgements as to whether the 'true sale' of the assets between the originator and the SPV have effectively taken place. However, these structured securities have come along with certification from the CRAs in which they assign ratings based on the expected economic loss of these securities. Further, CRAs have strongly influenced the bank capital requirements as they determine the risk weight on many assets⁸. Higher ratings mean less required capital. These factors drive issuers of structured finance securities to manufacture more AAA-rated structured finance securities so that they can access the large pool of potential buyers. To produce AAA-rated securities, originators require fulfilling the instructions assigned by CRAs. Structured finance securities let originator achieve this requirement by mean of two steps strategies including pooling and tranching.

While the construction of structured securities using, pass-through securitization is simple enough, the procedure of constructing an MBS becomes more complicated as the complexity of the underlying loans expands due to the remarkable degree of customization. Unlike private level MBSs, subprime mortgages are more complex as they are more sensitive to the housing market. This is because the performance of MBSs backed by subprime loans depends on the homeowner's ability to refinance and the prepayment of his current loan in full. To provide a better overview in the of process of creating complex structured securities with higher credit rating, we have chosen most relevant prototypical structured finance security- CDOs and exemplified in Figure 2. As the structured finance has developed into more complex financial mechanics prior to the financial crisis, CDO symbolizes this development in a unique way (Brunnermeier and Oehmke, 2009). The reason behind this security is considered complex is due to its complicated cash flow pattern which eventually played a key role in the financial crisis.

⁸Under Basel I rules, banks are required to hold 8% of core or tier one capital against their total risk-weighted assets.

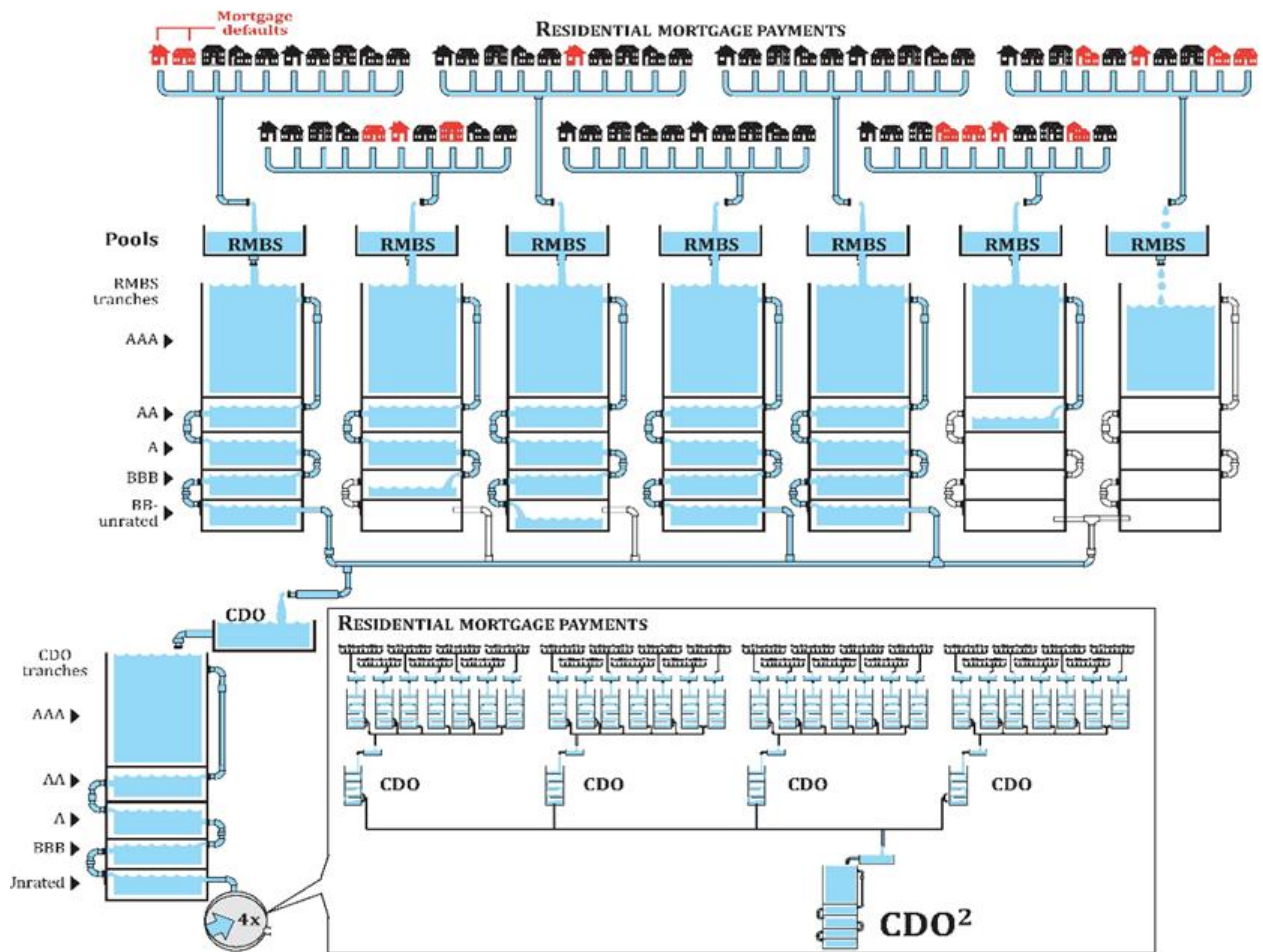

Figure-3. Overview of CDOs-squared structure

Source: <https://fcic.law.stanford.edu/img/2010-0602-aaa-assets-chart.pdf>

At the beginning of this complex process, a vast accumulation of residential mortgage loans is congregated in a portfolio. Usually, banks sell this collection of mortgages to SPV in exchange for cash. To issue and sell a number of residential mortgage-backed securities to the investors, SPV then uses the pool of these credit sensitive asset to construct these structured securities. The RMBS are sold as a range of securities with different cash flow risks, known as tranches which are rated by CRAs (shown in the second step of figure-II). Another way to construct highly rated securities with an increase in the total notional value involves re-securitization process using the lower rated tranches created in the first round. Within that re-securitization process, CDOs are created based on a pool of ‘mezzanine’ tranches obtained from the RMBS. The interesting feature of this repacking process is that CDO comprises 87 percent of the ‘senior’ tranches with higher credit rating (i.e. 75 percent AAA and 12 percent AA) where ‘mezzanine’ tranche is only 4 percent of CDO. Even though CDOs are constructed from the lower graded BBB tranche of RMBS, but end up with higher credit rating via ‘financial alchemy’ of the CRAs (Criado and Rixtel, 2008). The creation of safer tranches from the underlying collateral is mostly determined by the magnitude to which defaults are interrelated among the underlying assets. Since these ‘mezzanine’ tranches are backed by various mortgage pool, the interrelationship between different ‘mezzanine’ tranches are perceived to be lower. In the boom year of 2005 and 2006, CDO managers involved to the re-securitization process in which they purchased mezzanine tranches of subprime MBS as they were less attractive to the investors. By such multi-tranche securitization transaction, a new high quality structured product was created for risk averse-investors as identified by Beyer and Bräutigam (2013).

However, re-securitization process does not end with CDOs. The creation of CDOs from the tranches of other CDOs through re-securitization process are known as CDO-squared (Shown in the figure 3). Thus, reprocessing unsold CDOs into CDO-squared deals is an alternative way of staving off the final reckoning. As complex securities, have multiplied from CDOs to CDOs of CDOs (i.e. CDO-squared), the related tranching claim becomes more difficult to estimate as the particular tranches to the underlying asset pool is often very opaque. Thus, complexity has increased in each layer of re-securitization in an incremental fashion and recently designed structured securities are undoubtedly more complex than structured securities in the past. Thus, the incremental nature of the complexity through financial innovation made it harder and more difficult for market participants to understand these securities.

To explain a wide range of different transactions and effects of these complex structured finance securities, a nuanced understanding of the essence of the complexity might be critical to establish a meaningful investigation of its effects. However, the term 'complexity' is often difficult to define for a financial instrument as argued by Brunnermeier and Oehmke (2009). Thus, defining the complexity more narrowly might enable this study to examine the effects of complexity with greater precision which has covered into the next section.

4. WHY DOES COMPLEXITY MATTER?

Apart from the complex design of these structured securities, Awrey (2012) has identified six drivers of complexity in the structured finance market. These drivers of complexity can be classified into: technology, interconnectedness, fragmentation, opacity, regulation and reflexivity. Greater globalization and integration of financial institutions and markets have generated complex network linkage (known as interconnectedness) and importantly, immense fragility in the system. As these financial institutions and markets are so complex and so connected that any one part of the hyper-financial system can bring down the entire system (Crotty, 2009). Advance in financial theory⁹ and information technology¹⁰ have further enhanced the complexity by encouraging financial institutions to construct more complex and sophisticated structured finance securities. In the wake of global financial crisis, it has been broadly admitted that even the most sophisticated market participants have failed to catch the technical implications of these new securities and markets. However, the advance in technology and interconnectedness among these financial institutions have produced a significant source of opacity and thus complexity. These are in essence two kinds of opacity. First species of opacity arises from the simple non-availability of information within a particular segment of the marketplace. Second species of opacity arises from the enormous volume of information and technical difficulties which make it unobservable to the market participants (the information overload problem). Judge (2012) uses the term 'fragmentation nodes' to explain how a complex web has developed in each layer of re-securitization, for instance mortgage into ABS, ABS into CDOs and CDOs into CDO-squared. Regulation has also been considered as an important driver of complexity. Regulatory complexity arises from both substantive and structural elements. The recently enacted Dodd-Frank Wall Street Reform and Consumer Protection Act (2010) is a good example of substantive complexity as this Act contains 848 pages and require 243 new federal rules¹¹. Thus, the collection of these complicated rules undoubtedly place market participants to greater complexity as these rules may manifest a 'trillion unintended consequences'. Meanwhile, structural regulatory arises from the inevitable gap between growing globalization and interconnected structure of

⁹Breakthrough of more sophisticated theories include- Modern Portfolio Theory (MPT), Capital Asset Pricing Model (CAPM) and Black-Scholes Option Pricing Model as mentioned by Awrey (2012).

¹⁰In the context of finance, the breakthrough of information technology includes- 'emergence of financial science' based on sophisticated mathematical models as pointed out by *ibid*.

¹¹According to Copeland (2010), this estimate was made by New York law firm Davis Polk & Wardwell.

many financial institutions and markets (Awrey, 2012). Finally, the term 'reflexivity' is used to explain the intrinsic dynamism of modern financial market which is usually derived by previous discussed actors of complexity. Thus technology, opacity, interconnectedness, fragmentation, regulation and reflexivity certainly drive financial markets toward more complex environment. Now the question raises why complexity has not been considered as a subject to close scrutiny by the market participants or the regulators prior to the financial crisis. From the theoretical perspective, the implication of the 'complexity' has not seriously been observed by the classical asset pricing theories. The reason is that most of the asset pricing theories as like much of the economic theories are developed based on the assumption of 'rational framework' (Brunnermeier and Oehmke, 2009). Naturally, this assumption leaves very little scope to consider complexity as a determinant of the asset pricing. But for the better understanding of the different transactions and effects of these complex structured securities, a nuanced understanding of the complexity is essential. However, it is difficult to find a workable definition of 'complexity' of a financial instrument.

Based on Schwarcz (2009) complexity comes in at least two forms. First, complexity drives from complication and valuation difficulty which is known as 'cognizant complexity.' The notion of cognizant complexity is that things are just too complex to understand. Second, there is 'temporal complexity' which implies that complexity sometimes inadvertently transmitted too quickly to control in a complex system. Thus, Complexity in this sense derives from the intricate combining of parts, creating complications that increase the likelihood that failures will occur and diminish the ability of investors and other market participants to anticipate and avoid these failures.

5. HOW DID STRUCTURED FINANCE GO WRONG?

The breakdown of structured finance market was one of great puzzles of the financial crisis. The rapid growth of structured finance markets with lower defaults rate had indeed provided small ground to worry about the effectiveness of structured finance securities. The first reaction to the breakdown of structured finance was shocking: How could something as universally applauded as structured finance securities go so wrong? To examine how structured finance went so wrong, we have focused on the sources of complexities and thereafter how these sources had forced structured finance market to fall.

The emergence and steep growth of structured finance market was nothing but a complex market that had been driven by a complex bundle of supply-side and demand-side incentives as pointed out by Awrey (2012). To explain the motives for developing more complex structure securities, perhaps the most striking one was the strong investors' demand for AAA rated structured financial securities. The issuance of these complex structured securities within the U.S. economy alone had enhanced to more than ten-fold in under a decade. This was because complex securities backed by the pool of assets (such as subprime loans and CDOs backed in part by MBSs) tended to provide comparatively high yields relative to the traditional securities (Schwarcz, 2009). In response to these outsized demands and heterogeneity of investors, financial institutions began to offer a broader menu of complex financial securities with particular characteristics (like AAA rating) through securitization. Institutional investors such as hedge funds, pension funds, and insurance companies started to demand high yield risky and complex securities. This was because of their higher credit rating and attractive higher yield rate than the rating-matched alternative, corporate bonds. Thus, the creation of complex structured securities enabled financial institutions to collect fees simultaneously from investors and absorb regulatory loopholes in bank regulation and supervision. But the 'systemic market failure' of these structured securities raises the primary question of why did so many investors of structured finance securities make so many wrong decisions? How could big investment banks sell these so questionable complex securities so easily? One passable explanation documented by various literatures is that financial institutions developed overly complex structured securities to divert investors' attention in a particular way to take advantages. In a world with complete information, once the financial institutions have more information than the investors about some not easily recognizable features of these loans, then financial institutions

intentionally design excessively complex securities. The key motives behind this complexity is to distract investors so that they cannot find out the problematic nature of loans. An Empirical investigation of Célérier and Vallée (2014) based on a lexicographic analysis of the prospectus of 55,000 products shows that more the complex a structured finance security is, the more profitable it is for banks. Thus, enhanced complexity in the architecture of the structured finance could be a passable way to distract investors. One of the technical ways to increase the complexity would be to enhance deal size. Usually, larger deals include more loans, various types of underlying collateral, and more geographic dissimilarity. Thus, the increased deal size makes it harder for investors to examine how the behaviour of any single loan could change the return of the security they hold (Furfine, 2014). Another key source of enhancing complexity involves with the increasing number of pooling and tranching in the deal. When the pool consists of a vast number of heterogeneous assets, it becomes difficult to evaluate the risk and return of a structured security from its underlying asset pool. However, additional tranching increases the extra layer of analytical complexity. Investment banks buy the loans for the inclusion in a MBS and divide their cashflows into CDO that had been further used for the construction of structured claim against the underlying pool of assets. Due to the nonlinear connection between underlying loans performance and security returns, tranching process allows investment banks to issue more complex securities (such as CDO) in both the registered and unregistered markets (Fender and Mitchell, 2005). However, Foote *et al.* (2012) argue that during the credit boom, potential investors had received a great deal of detailed information regarding the pool of loans from the issuers. It is true that investors had the access to the enormous volume of data, but they were publicly obtainable in a strictly technical sense. This is because, considering a CDO, a single MBS might contain various thousands of mortgages followed by a single CDO contains 150 MBS¹² and a CDO-squared might contain further several CDOs. Since these structured securities are constructed by using exponentially increasing number of reference assets, a considerable amount of both legal and financial data as well as the documentations might be required to conduct a multi-faceted analysis to valuing a single CDO investment (Crotty, 2009). While being practical to use these securities, it is still difficult to extract a generalized model or method that can manage these complex calculations. As the complex securities have magnified from CDOs to CDO-squared or CDOs and CDOs squared to CDO-cubed, it becomes harder and more difficult for any investors to understand the constitution and quality of underlying assets. In addition to the complex structured securities, financial asset (mortgage loan products) might also be complicated due to their terms and conditions. To meet the market demand, issuers designed diverse products with varied terms including adjustable rate, low-to-zero down payment requirements, interest only payment options and negative amortization. Because of these varied terms and conditions, it became more complicated for the borrowers to understand fully the level of risk they were incurring.

Investment banks have also come under criticism for their dual role in global financial crisis. Due to the extensive short-term return from structured finance securities, investment banks had begun to concentrate more on securitization and trading these securities on their own account rather than their traditional advising activities. The complexity began to appear when the spectacular profit growth of investment banks and investors were highly tied up with the buying and selling behaviour of these complex securities. The terrifying fact was that while making substantial gain out of these complex securities, the investment banks sensed that investors were going to lose their money, but they did not bother. This was because of their no 'skin in the game' position as they did not require reimbursing their contentious earnings when the inevitable crisis takes place and hence suffer no losses. Based on the previous evidence, few Wall Street executive perceived that complex structured securities were literally a ticking time bomb in the central to the boom and eventually it would explode someday, but they had little incentive to shift their business as mentioned by Coval *et al.* (2009). Initially, the parties involved in the booming investment banks' profit included various institutional investors. Among those institutional investors, hedge funds had played a

¹² A typical CDO can comprise as many as 150 other packages of securities. For further discussion, see Myers (2013).

critical role in creating a complex and unregulated environment. Due to the lack of regulation and supervision on hedge funds activates, they were more encouraged to take a risky position to gain the superior return. To intensify their earnings, hedge funds enhanced their exposures by employing complex structured securities backed by derivative obligations rather than by more traditional securities (Bavoso, 2013). Moreover, institutional investors were more likely susceptible to herd behaviour as they were making immense short-term gain by investing in these complex structured securities. To maintain competitive advantage, they had very little incentives to move their investments to the side-lines even if the financial crisis arises in the near future (Awrey, 2012). However, things were getting more complicated once investment banks had found a way to sell their structured finance securities beyond their traditional institutional investors. Under the security laws, high net worth investors categorized as 'accredited investors'¹³ can purchase unregistered structured securities where for retail investor these securities have to be registered. In response to that investment banks began to offer the different form of retail structured securities through their brokerage networks.

The global financial crisis might not have happened at all if CRAs had not provided ridiculously high ratings to these complex structured finance securities (Crotty, 2009). Since structured finance market evolved as 'rated' market, the issuers of these securities were eager to receive a favourable rating on the identical scale as corporate bonds. If CRAs did not provide these critical ratings, then the institutional investors such as mutual funds, pension funds would have barred by their own rules from buying these immensely complex securities. Consequently, the potential buyer would have distinguished these securities as a very complex derivative security. To understand the failure of the rating process in the structured finance market, we have examined how and why CRAs were drastically overrated these complex securities. Part of the explanation lies in the intricate design of these securities as these securities were new innovation and investors know less about the quality of these complex securities. Consequently, the emergence of these new securities and their complex construction in all likelihood enhanced the importance of CRAs as 'delegated monitors' (Fender and Mitchell, 2005). In rating process, expected probability of defaults (EPDs) or expected loss rate (ELR) is employed to estimate the default risk of debt instruments. To evaluate the EPDs or ELR of each tranche for a structured finance security, the CRAs require characterizing the size and position of that tranche to compare future cash inflows produced by underlying collateral pool as pointed out by Griffin and Tang (2012). The construction of traditional ABSs are based on large homogeneous pools of the asset which are well diversified with no significant individual exposure relative to overall pool size. But when it comes to assign rating to the more complex structured CDOs, CRAs have faced enormous challenges as the rating process for the CDOs are different from the traditional ABS. Consequently, the complex structure of CDOs further intensifies the effect of imprecise assumptions about the probability of default, recovery rate, default correlation and model error (Skreta and Veldkamp, 2009). However, these traded complex securities were so new and untested that CRAs had no historical return data to analyse their creditworthiness. Therefore, CRAs had been compelled to generate reasonable estimates of default rates and related losses entirely from an unrepresentative real-world data. Difficulties for CRAs had further accentuated when financial institutions began to re-securitize the CDOs of CDOs tranches to produce CDO-squared. Due to the lack of historical data on complex CDOs, the CRAs were impelled to make many possible conclusions based on different methodologies and assumptions to deliberately provide inflated ratings (Skreta and Veldkamp, 2009). CRAs have further criticised for their commercially conflicting activities as they are paid by the issuers to rate their securities which may be led to the conflict of interest. Greater the rating differences among the CRAs, stronger the issuers incentive to selectively disclose (shop for) ratings. Griffin *et al.* (2013) refer rating shopping as a situation in which issuer explore ratings from different CRAs and select the most advantageous one. Based on Skreta and Veldkamp (2009) the connection between the ratings shopping and security

¹³ Accredited investors, a category that includes individuals with at least \$1 million in net worth (including the equity in their real estate holdings), \$200,000 in individual income or \$300,000 in joint income.

complexity has two directions. Firstly, the issuer might want to issue even more complex securities to obtain a wider list of ratings to select from. Secondly, the issuance of more complex securities might push CRAs to make judgement call as they might not have enough historical data to make the better assessment. Further, Skreta and Veldkamp (2009) demonstrate that if issuer involves in ratings shopping, given ratings will be systematically biased upward as the securities get more complex. Apart from the credit shopping, credit catering has further enhanced the complexity in which CRAs involve in catering their ratings to the issuers to maximize their consulting fees as mentioned by Ghent *et al.* (2014). It seems that CRAs do not completely acknowledge their critical involvement in rating complex structured finance securities and the fragility of their estimates rather they claim these ratings as merely an 'opinion'. Thus, the excessive complex structure of the structured finance securities pushes CRAs to make unrealistic assumptions to produce inflated AAA rating.

6. CONCLUSION AND RECOMMENDATIONS FOR FURTHER STUDIES

The study found that excessive complexity in the design, securitization process and documentation of financial transactions certainly contributes to the failure of market participants and the fall of structured finance market. Structured finance involves highly complex securities and techniques in which only a small circle of financial market experts may have complete understanding. Investors in complex structure finance securities tend to restrain themselves from independent judgement on the quality of these products as these securities are more complicated to understand. Before the global financial crisis, market participants actually thought that structured finance securities were a good deal. As the financial crisis spread out, the world had observed an unparalleled rate of default on AAA-rated structured securities which were widely considered to be the safest investment. A massive portion of structured securities saw their ratings downgraded. Even the AAA rated tranches of CDOs underwritten by Merrill Lynch observed their securities downgraded to 'junk' securities. Sub-prime meltdown has further revealed that the severe complexity exists at every point of the securitization process due to the poor documentations. Lack of documentations drives financial intermediaries to engage in more complex securitized structures for allocating and reallocating cashflows from questionable loans and the obscurity off-balance-sheet vehicles to manufacture complex structured securities. Financial institutions further use complexity as a mechanism to distract investors. Because of the complex structure of the security, investors have placed their reliance on the investment banks and rating agencies for 'due diligence' purposes. It is also tempting to blame investment banks and CRAs for the fall of structured finance market. Although there is certain evidence that CRAs and investment banks have made some remarkable mistakes. But the fact is that investment banks and CRAs cannot do due diligence on tens of thousands of mortgages that might be contained in a CDO. This is primarily because complexity enhances the amount of information in each layer of the securitization process and it involves the higher cost for financial institutions to analyse this extra information. Moreover, no financial institutions had that time, the incentives and the ability to assess the complexity and the risk associated with each of the tens of thousands of mortgages that might be comprised in a CDO. So, it could be still difficult for market participants to estimate the risk of the CDO duly even if they had complete information because of their complex and nonlinear connection between the value of CDO and mortgages. Further, none of these institutions know the true probability of possible upcoming situation because the related complexity of these securities has grown exponentially along with the number of reference assets. Thus, this leads to the fewer incentives for investment banks and CRAs to completely understand the highly complex securities in which they recommend their institutions to invest. Instead of that, they depend on the simulation models to estimate the risk of CDOs and their tranches. Apart from the complex design of the structured finance securities, greater globalization and integration of these financial institutions have certainly exacerbated the complexity to the unusual level. This process has generated complex network linkage as financial institutions are become ever more interlinked (through counterparty arrangement) and ever more complicated. Consequently, complexity has created immense fragility in the system that makes it costlier to identify and monitor the potential

source of risk within the financial system. In fine, tackling financial complexity is undoubtedly the greatest challenge in the 21st century. In the study, a number of problems demanding furthermore intensive research including (1) regulatory frameworks for reducing financial complexity, (2) the analysis methodology of financial complexity and (3) pricing complexity in an asset pricing model.

Funding: This study received no specific financial support.

Competing Interests: The authors declare that they have no competing interests.

Contributors/Acknowledgement: Both authors contributed equally to the conception and design of the study.

REFERENCES

- Awrey, D., 2012. Complexity, innovation and the regulation of modern financial markets. *Harvard Business Law Review*, 2(2): 235-294.
- Bavoso, V., 2013. Financial innovation and structured finance: The case of securitisation. *Company Lawyer*, 34(1): 3-12.
- Beyer, K.M. and L. Bräutigam, 2013. CDOs—A critical phenomenon of the financial system in the crisis. ICAE Working Paper Series No. 21. Retrieved from <https://www.jku.at/icae/content/e248904/e248907/e249185/e249192/wp21b.pdf> [Accessed 2016 August 03].
- Brunnermeier, M.K. and M. Oehmke, 2009. Complexity in financial markets. Princeton University, Working paper Series. Retrieved from <http://www.princeton.edu/~markus/research/papers/Complexity.pdf> [Accessed 2016 August 04].
- Célérier, C. and B. Vallée, 2014. The motives for financial complexity: An empirical investigation. HEC Paris Research Paper No. FIN-2013-1013. Retrieved from <http://bogan.dyson.cornell.edu/ibhf/docs/Symposium%20Papers/FinancialComplexity.pdf> [Accessed 2016 August 10].
- Copeland, C.W., 2010. Rulemaking requirements and authorities in the dodd-frank wall street reform and consumer protection act. CRS Report for Congress No. R-41472, Congressional Research Service, Washington DC. Retrieved from <https://llsdc.memberclicks.net/assets/DoddFrankdocs/crs-r41472.pdf> [Accessed 2016 August 12].
- Coval, J., J. Jurek and E. Stafford, 2009. The economics of structured finance. *Journal of Economic Perspectives*, 23(1): 3-25. *View at Google Scholar*
- Criado, S. and A.V. Rixtel, 2008. Structured finance and the financial turmoil of 2007-2008: An introductory overview. Banco de Espana Occasional Paper No.0808. Retrieved from http://papers.ssrn.com/sol3/papers.cfm?abstract_id=1260748 [Accessed 2016 August 04].
- Crotty, J., 2009. Structural causes of the global financial crisis: A critical assessment of the 'new financial architecture'. *Cambridge Journal of Economics*, 33(4): 563-580. *View at Google Scholar | View at Publisher*
- Fabozzi, F.J., H.A. Davis and M. Choudhry, 2006. Introduction to structured finance. New Jersey: John Wiley & Sons, Inc.
- Fabozzi, F.J. and V. Kothari, 2007. Securitization: The tool of financial transformation. Yale International Center for Finance Working Paper No. 07-07. Retrieved from http://papers.ssrn.com/sol3/papers.cfm?abstract_id=997079 [Accessed 2016 August 03].
- Fender, I. and J. Mitchell, 2005. Structured finance: Complexity, risk and the use of ratings.
- Foote, C.L., K.S. Gerardi and P.S. Willen, 2012. Why did so many people make so many ex post bad decisions? The causes of the foreclosure crisis. National Bureau of Economic Research Working Paper No. 18082. Retrieved from <http://www.nber.org/papers/w18082.pdf> [Accessed 2016 August 03].
- Furfine, C.H., 2014. Complexity and loan performance: Evidence from the securitization of commercial mortgages. *Review of Corporate Finance Studies*, 2(2): 154-187. *View at Google Scholar | View at Publisher*
- Ghent, A.C., W.N. Torous and R.I. Valkanov, 2014. Complexity in structured finance. Working Paper. Retrieved from http://papers.ssrn.com/sol3/papers.cfm?abstract_id=2325835 [Accessed 2016 August 10].

- Griffin, J.M., J. Nickerson and D.Y. Tang, 2013. Rating shopping or catering? An examination of the response to competitive pressure for CDO credit ratings. *Review of Financial Studies*, 26(9): 2270-2310. [View at Google Scholar](#) | [View at Publisher](#)
- Griffin, J.M. and D.Y. Tang, 2012. Did subjectivity play a role in CDO credit ratings?. *Journal of Finance*, 67(4): 1293-1328. [View at Google Scholar](#) | [View at Publisher](#)
- Judge, K., 2012. Fragmentation nodes: A study in financial innovation, complexity, and systemic risk. *Stanford Law Review*, 64(3): 657-726.
- Myers, D., 2013. *New economic thinking and real estate*. New Jersey: John Wiley and Sons Inc.
- Schwarcz, S.L., 2008. Protecting financial markets: Lessons from the subprime mortgage meltdown. Duke Law School Legal Studies Paper No. Retrieved from <http://ssrn.com/abstract=1107444> [Accessed 2016 August 03].
- Schwarcz, S.L., 2009. Regulating complexity in financial markets. *Washington University Law Review*, 87(2): 211-268. [View at Google Scholar](#)
- Skreta, V. and L. Veldkamp, 2009. Ratings shopping and asset complexity: A theory of ratings inflation. *Journal of Monetary Economics*, 56(5): 678-695. [View at Google Scholar](#) | [View at Publisher](#)
- Tavakoli, J.M., 2008. *Structured finance and collateralized debt obligations: New developments in cash and synthetic securitization*. 2nd Edn., New Jersey: John Wiley and Sons Inc.
- World Economic and Financial Surveys, 2008. *Global financial stability report: Containing systemic risks and restoring financial soundness*. International Monetary Fund, Washington DC. Retrieved from <https://www.imf.org/External/Pubs/FT/GFSR/2008/01/pdf/text.pdf> [Accessed 2016 August 02].

Views and opinions expressed in this article are the views and opinions of the author(s). Asian Economic and Financial Review shall not be responsible or answerable for any loss, damage or liability etc. caused in relation to/arising out of the use of the content.