



## JOB SATISFACTION, EMPLOYEE LOYALTY AND JOB PERFORMANCE IN THE HOSPITALITY INDUSTRY: A MODERATED MODEL



 **Tran Thi Kim  
Phuong<sup>1</sup>**

<sup>1,2</sup>University of Economics, The University of Danang, Danang City,  
Vietnam.

<sup>1</sup>Email: [phuong.ttk@due.udn.vn](mailto:phuong.ttk@due.udn.vn) Tel: (+84)903517108

 **Tran Trung Vinh<sup>2+</sup>**

<sup>2</sup>Email: [vinhtt@due.udn.vn](mailto:vinhtt@due.udn.vn) Tel: (+84)914301309



(+ Corresponding author)

### ABSTRACT

#### Article History

Received: 19 March 2020

Revised: 30 April 2020

Accepted: 2 June 2020

Published: 22 June 2020

#### Keywords

Job satisfaction  
Employee loyalty  
Job performance  
Job positions  
Hospitality industry  
SEM.

Examining the interrelationships among job satisfaction, employee loyalty, and job performance in the hospitality sector in Vietnam is rarely done. This study provided a deeper understanding of the relationships between job satisfaction, employee loyalty and job performance, and the effect of job positions as a moderator on these relationships. This study synthesized theories from past research to derive a conceptual model to clarify this phenomenon. This work applied structural equation modelling (SEM) and a multi-group analysis to test four hypotheses, with data from 315 employees of lodging enterprises in Danang city, Vietnam. Empirical results showed that: (1) job satisfaction has a positive direct impact on employee loyalty and job performance; (2) employee loyalty positively affects job performance; and, (3) the effect on the relationship between job satisfaction and employee loyalty differs by job position. Lastly, these findings have implications for lodging managers.

**Contribution/ Originality:** The paper's primary contribution is finding that job position is a significant moderator impacting the relationships among job satisfaction, employee loyalty and job performance. This paper provides important implications for managers in the Danang hospitality industry through theoretical and practical contributions.

## 1. INTRODUCTION

Tourism is a “smokeless industry”, a phenomenon which currently contributes significantly to the success of the global economy. Tourism and travel contribute directly to GDP, directly accounting for more than 2.3 trillion USD, with the value of world tourism exports estimated at more than 14 billion USD (The World Travel & Tourism Council, 2018). With such great contributions to the global economy and society in general, the tourism industry is focused on the development of investment (Tran & Tran, 2017; Wang, Tran, & Tran, 2017). This is demonstrated by the total investment for tourism and travel, reaching about 8 trillion USD, equivalent to about 4.4% of the total global economic investment.

Tourism in Vietnam has also made dramatic improvements. Vietnam ranked 3rd in the top 10 countries with the highest number of international tourists in 2017 (Vietnam National Administration of Tourism, 2018b) with total revenue from tourism accounting for 500 trillion VND in 2017, up by 27.5% in comparison to 2016 (Vietnam National Administration of Tourism, 2018a). The Vietnamese tourism sector is expected to contribute to growth in

the GDP of about 7.2% per year in the near future, reaching nearly 600 billion VND in 2026 (The World Travel & Tourism Council, 2018).

Danang is in central Vietnam, playing a crucial part in the socio-economic growth of Vietnam in general and the Central Highlands region. With the advantages of natural conditions, especially favorable tourist location, Danang is an attractive destination for tourists and is tipped to be at the top of the list of the brightest destinations (Tran, Vo, Cao, & Doan, 2015; Tran, Nga, & Nguyen, 2017) in Vietnam. In the period from 2011 to 2016, the growth rate in the number of tourists to Danang averaged 20.97%, and average revenue growth stood at 31.59% (Danang Department of Tourism, 2018).

The hospitality industry is a significant part of putting up the growth of the tourism industry in Danang. In recent years, Danang's hospitality industry has boomed. Figures have risen from a total of 260 accommodation establishments with 8,736 rooms in 2011 to 693 accommodation establishments with 28,780 rooms in 2017 (Danang Department of Tourism, 2018).

The rapid increase in the number of accommodation enterprises has led to fierce competition in this sector; as such, the demand for human resources has increased sharply. According to preliminary statistics from the Vietnam National Administration of Tourism, the tourism industry in Vietnam requires an additional 40,000 employees annually, and this number is forecasted to increase to a total workforce of about 870,000, with a projected growth rate of 7% per year, in the period from 2016-2020 (Nguyen, 2016). At least 30% more staff are needed in the hospitality industry itself; this demand forces businesses to raise wages to attract workers, which in turn leads to increased operating costs (Truc, 2017).

To create a difference to enhance their competitiveness, businesses are constantly seeking and improving the elements of business operations. People are considered as a key weapon and a sustainable competitive advantage in the success of accommodation enterprises, while other factors can be easily imitated by competitors (Santa, López-Guzmán, & Cañizares, 2014). In addition, revenue in the hospitality industry is mainly contingent upon employee turnover (Gazioglu & Tansel, 2006).

However, many accommodation enterprises are facing difficulties in recruiting and retaining laborers. One of the reasons is that employees can easily change their work environment by willingly relocating to different workplaces for better positions and improved welfare conditions (Tran & Tran, 2017). When long-term employees quit their jobs, enterprises incur high costs in training new employees (Chaturvedi, 2010). With the unpredictable business environment and intense business competition, employees play a crucial role for almost companies; as such, examining the job satisfaction, job performance, and employee loyalty has recently gained growing attention in the tourism field.

Previous work confirmed the relationships between job satisfaction and employee loyalty (Abdullah et al., 2009; Hussain, 2012; Waqas et al., 2014; Yin, Fen, Meng, Yin, & Jack, 2012) job satisfaction and job performance (Dugguh & Dennis, 2014; Muindi & K'Obonyo, 2015; Nabi, Syduzzaman, & Munir, 2016) and employee loyalty and job performance (Brown, McHardy, McNabb, & Taylor, 2011; Elegido, 2013). Findings from previous studies confirmed positive relationships among job satisfaction, employee loyalty and job performance. In short, when employees have higher satisfaction regarding their job position and working environment, the probability of their resignation or retirement will be lower. In addition, job satisfaction in employees will lead to higher work performance and higher efficiency for businesses (Almutairi, Moradi, Idrus, Emami, & Alanazi, 2013). In addition, Heskett, Sasser, and Schlesinger (1997) proposed the profit chain model to fully explain the connections among profit growth, customer satisfaction, service value and employee satisfaction.

Although there have been many previous studies on the correlations among job satisfaction, employee loyalty and job performance, there exists little investigation regarding the hospitality industry in Vietnam. Differences in demographic characteristics, job positions, work experience, salary, and total working tenure among employees also affect their perception of satisfaction, loyalty and performance.

This study was conducted to fully explain the relationships between job satisfaction, employee loyalty and job performance, as well as the effect of moderating variables on these relationships. To achieve this, this study synthesized theories from past research to derive a theoretical model which clarifies this phenomenon. This work examined a conceptual model via conducting empirical research for Danang's hospitality industry and used the structural equation model (SEM), which has been commonly applied in past studies and various fields (Hair, Ringle, & Sarstedt, 2011; Hershberger, 2003) to examine multivariate dependence relationships simultaneously. Besides theoretical contributions, this study also provides important implications for lodging managers.

## 2. LITERATURE REVIEW

### 2.1. Research Concepts

#### 2.1.1. Job Satisfaction

Job satisfaction has an important role in the success of any organizations. Job satisfaction is considered to evaluate the extent of fulfillment a job brings an employee which consequently influences that employee's conduct and job performance. It is challenging to establish job satisfaction, but by doing so, employees will feel comfortable and excited to innovate their job (Syptak, Marsland, & Ulmer, 1999). Therefore, the study of employee job satisfaction is a vital issue, especially for service organizations such as those within the hospitality sector, particularly as the employee is an essential element in the process of service delivery from business to customer.

Most job satisfaction definitions outline a complex and multi-dimensional picture (Volkwein & Parmley, 2000). According to Hoppock (1935) job satisfaction refers to a mix of cognitive, physiologic and environmental factors that make a person satisfied or dissatisfied with his/her work. Job satisfaction represents the positive or negative emotions of workers toward their job position. Similarly, Vroom (1964) also considers that employee job satisfaction is emotionally-oriented concerning the work they are performing. Once employees are satisfied with their work, they will have a positive attitude towards it and vice versa (Armstrong, 2006).

From another approach, researchers believe that job satisfaction is the outcome of a comparison between an employee's expectations and the actual results related to their work (Mason & Griffin, 2002; Wright, 2006). Job satisfaction reflects the perception of employees from the results of job awareness that meets their physical and psychological needs (Aziri, 2011). It is evident that employee job satisfaction is higher if their high expectations are met, meanwhile, the prediction of their ability to quit will be higher without the satisfaction of their work (Alexander, Lichtenstein, Oh, & Ullman, 1998).

#### 2.1.2. Employee Loyalty

Employee loyalty also is a common area of interest for researchers and employers. Loyal employees importantly contribute to the development of any companies. The value of employee contributions to the business will increase with their working time at the company. Hence, a company's policies always are aimed at growing employee loyalty to facilitate their lengthy tenure. Many companies point to a difficult situation and losses in profits due to employee departures. The frequent departure of employees can impact the effectiveness and spirit of those who remain in the enterprise.

Employee loyalty is defined in various ways. Loyalty means a demonstration of one's commitment to an organization, typified by the relative advantage of a person's identification with, and active engagement in, the operations of a firm (Mowday, Steers, & Porter, 1979). When the employee believes in the values, mission and statements of an organization, it can manifest an intense aspiration to keep a relationship with that enterprise, a phenomenon described in a word as loyalty (Mathieu & Zajac, 1990). Bettencourt, Gwinner, and Meuter (2001) also indicated that employee loyalty is an organizational behavior that expresses adherence to the firm to increase interests. In other words, loyalty is a psychological state that emphasizes the correlation between labors and the

company, in turn impacting the decision of a worker to carry on with a particular organization (Allen & Grisaffe, 2001).

In terms of the hospitality industry, loyalty can manifest itself in employees, such as effort and creativity in work, respect for organizational culture and obedience to superiors' orders (Costen & Salazar, 2011; Matzler & Renzl, 2006). Once employees are loyal to the business, they will fully believe in the goals of the organization and work for the common goals of the company and want to stick with the business for a long time.

### 2.1.3. Job Performance

The ultimate target of business owners is profitability; the success of an organization also relies on employee performance, as poor performance hampers an enterprise's ability to succeed. The success of a firm is normally based on the organization broadly building upon the performance of each employee (Pushpakumari, 2008). It is quite clear that those demonstrating better performance will have a higher preference in being hired compared to those who do not perform as well. High achievers are needed to fulfill an organization's missions and statements and to continue the genesis of competitive advantages (Sonnentag & Frese, 2002). Therefore, to increase productiveness in an organization, the firm needs to identify and exploit solutions which can advance the job performance of employees.

There exist various definitions for the concept of job performance. Javed, Balouch, and Hassan (2014) defined job performance as generally referring to whether a worker carries out his/her duty well or not. Aguinis (2009) also indicated that "the definition of performance does not include the results of an employee's behavior, but only the behaviors themselves". Performance refers to the behavior or actions of employees, not the production or the outcome of their work. In another study, performance is considered as a function of an individual ability/skill/effort in a given situation (Lawler & Porter, 1967). Job performance also is "the total expected value to the organization of discrete behavioral episodes that an individual carries out over a standard period" (Motowidlo, 2003). Task performance and contextual performance are two components to measure employee job performance (Kahya, 2009).

In terms of the hospitality industry, the job performance of employees is categorized as when workers apply their specific knowledge and skills to accurately conduct their tasks according to the standard service procedures of accommodation establishments. Employees perform various tasks within the organization, primarily providing guests with functions such as accommodation services, catering services and other additional services and jobs related to features such as finance, accounting, marketing, sales and personnel. All these activities performed by the staff are related to the organization's goals.

## 2.2. Relationships among Research Concepts

Previous studies conducted to measure the job satisfaction of employees; as such, it is defined as an essential element determining employee loyalty, job performance, and a business's development and stability (Angle & Perry, 1981; Riketta, 2002).

The organization must satisfy employees to make them loyal. It means that the lower the worker's satisfaction leads to the higher the job leaving (Moblely, Griffeth, Hand, & Meglino, 1979). In short, satisfied employees will become loyal when the firm gives them a chance to learn and grow; this employee loyalty manifests by developing their job satisfaction. In that way, all workers will be a part of making organizations successful, having greater satisfaction and eventually developing higher loyalty (Anne & Grønholdt, 2001; Arsić, Nikolić, Zivković, Urošević, & Mihajlović, 2012; Eskildsen & Nussler, 2000; Javed et al., 2014).

Arsić et al. (2012) carried out an empirical study to collect data from 261 employees to examine the effect of job satisfaction on employee loyalty. Findings found that the higher the job satisfaction, the more loyal senior employees were. Other findings from the study of Javed et al. (2014) demonstrated that there is a positive correlation between worker loyalty and job satisfaction with  $\beta = 0.415$  and  $p\text{-value} = 0.000$ , meaning job satisfaction

contributes more than 41% to the loyalty of employees. This positive relationship was also confirmed by [McNeese-Smith \(1996\)](#); [Fosam, Grimsley, and Wisher \(1998\)](#); [Fu and Deshpande \(2014\)](#). In terms of the hospitality industry, previous studies also confirmed the positive impact of employee job satisfaction on employee loyalty ([Chen, Tsui, & Lee, 2017](#); [Costen & Salazar, 2011](#)).

Thus, this study suggested that job satisfaction influences employee loyalty. From that assumption, the following hypothesis was formulated:

*H1: Job satisfaction of employees has a direct positive effect on employee loyalty.*

It is a fact that the job efficiency which workers perform will be higher when they do it with high satisfaction. This is shown in previous studies ([Javed et al., 2014](#); [Wright, Cropanzano, & Bonett, 2007](#); [Yvonne, Rahman, & Long, 2014](#)). For example, an empirical study by [Yvonne et al. \(2014\)](#) demonstrated that there is a positive impact of employee job satisfaction on employee job performance via collecting data from 77 workers working at 24 stores in the Kepong area, Wilayah Persekutuan, Kuala Lumpur.

[Javed et al. \(2014\)](#) conducted a study on a sample of 150 employees in Bahawalpur. The study found that job satisfaction has an influence on job performance. Job satisfaction contributes 14% to job performance, meaning job efficiency of employees was explained by how employees satisfy their job. Within the hospitality industry context, past studies also investigated this correlation (e.g., ([Almutairi et al., 2013](#); [Fisher, 2003](#); [Gu & Siu, 2009](#); [Nimalathan & Brabete, 2010](#); [Prasanga & Gamage, 2012](#); [Tsai, Cheng, & Chang, 2010](#))).

Thus, this study suggests that job satisfaction influences job performance. From that, the following hypothesis was formulated:

*H2: Job satisfaction has a direct positive effect on job performance.*

Employee loyalty plays a vital role in enhancing organizational performance. It can be explained that loyal employees might perform better because they generally look at the bigger picture. They work not because of salary or responsibility, but because they want to pursue their passions and interests in their career path. Therefore an employee working with loyalty is more likely to increase the organization's performance for which they are in charge ([Elegido, 2013](#)). Based on the findings from previous research, employee loyalty has a positive correlation and unique contribution in determining job performance ([Brown et al., 2011](#); [Chughtai & Zafar, 2006](#); [Darolia, Kumari, & Darolia, 2010](#); [Razzaq, Ayub, Arzu, & Aslam, 2013](#)). For example, examining the relationship between employee loyalty and job performance is the aim of the study by [Brown et al. \(2011\)](#). This study used data from the 2004 UK workplace and obtained result about the positive effect of loyalty workers on job performance. Thus, this study suggests that employee loyalty influenced job performance. From that, the following hypothesis was formulated:

*H3: Employee loyalty has a direct positive effect on job performance*

Based on [Maslow \(1943\)](#) the Two Factors Theory by [Herzberg, Mausne, and Snyderman \(1959\)](#) and [Vroom \(1964\)](#) there is the impact of many factors considered as moderating variables in bringing job satisfaction for employees, thereby enhancing employee loyalty and job performance. Human needs are classified into five categories, and basic needs must be met before higher requirements. The more jobs that allow individuals to grow and achieve higher levels of demand, the easier it is for individuals to achieve job satisfaction ([Ali, 2016](#)). Thus it can be seen that through [Maslow \(1943\)](#) in order to evaluate the employee job satisfaction, it is highly essential to determine the needs or concerns of employees in relation to the level of demand. In addition, the Two Factors Theory by [Herzberg et al. \(1959\)](#) has divided elements of satisfaction and non-satisfaction into two groups: motivational factors and hygiene factors. The motivational group relates to factors such as the nature of the work, recognition, promotion potential, and responsibility. This group, when satisfied, will bring satisfaction to employees. Hygiene factors will help employees achieve a positive attitude and reduce discontent in terms of supervision, salary, working conditions, relationships with colleagues, and job position. [Vroom \(1964\)](#) proposed three variables to consider expectancy, instrumentality, and valence. This theory shows the interaction between

individual variables within the workplace and is associated with employee expectations. Employees feel satisfied when receiving a salary for their efforts commensurate with their level of expectations regarding job position. Differences between expectations and actualities will not bring job satisfaction to employees.

From the above discussion, this study assumed that the process of determining the degree of relationships among job satisfaction, employee loyalty and job performance in the hospitality industry would be impacted by job position. As a result, the following hypotheses were established:

*H4a: The impacts of job satisfaction on employee loyalty differ between standard employee positions and positions at the supervisory level and above.*

*H4b: The impacts of job satisfaction on job performance differ between standard employee positions and positions at the supervisory level and above.*

*H4c: The impacts of employee loyalty on job performance differ between standard employee positions and positions at the supervisory level and above.*

As a result, a conceptual model [Figure 1](#) was established with three constructs showing the relationships among research concepts.

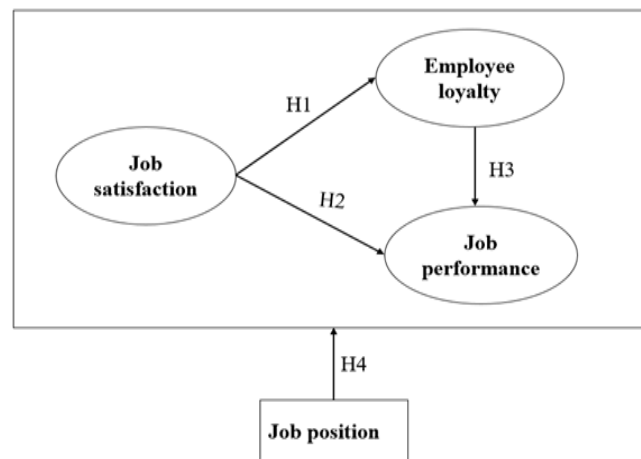

**Figure-1.** Conceptual framework.

### 3. METHODOLOGY

#### 3.1. Study Context

The Danang hospitality industry was chosen for this study. Although people are a key factor in creating competitive advantages for accommodation businesses, the recruitment/retention of workers is nonetheless complicated for lodging business operations in Danang. Therefore, it is highly essential for lodging managers to deeply understand of the interrelationships among job satisfaction, employee loyalty and job performance based on the responses of workers who have been working in the Danang hospitality industry.

#### 3.2. Content Validation

After proposing the research model, this study analyzed the specific characteristics of the conditions of the hospitality industry in Danang and adapted items of factors from previous studies. In particular, six items used to assess job satisfaction were adapted from the study of [Homburg and Stock \(2005\)](#) four items for employee loyalty were adapted from [Costen and Salazar \(2011\)](#) and six items for job performance were from [Almutairi et al. \(2013\)](#).

All measuring items of scales must ensure reliability ([Allen & Yen, 1979](#)) and internal consistency ([Nunnally, 1978](#)). To examine the theory, it was highly essential for verifying content validity ([Hair, Black, Babin, & Anderson, 2010](#)). Thus, preliminary research was done by gathering opinions from the targeted respondents to test the latent variables and modify them, if needed. If the measuring items were verified in terms of requirements and



content, they were included in the questionnaire. This work then performed one pilot study with twenty respondents working in the Danang hospitality industry. As Cronbach's alpha values of all factors were greater than 0.7, the result showed that all dimensions were acquiring good reliability (Nunnally & Bernstein, 1994).

### 3.3. Research Instruments

This study designed the survey question, including the three dimensions with sixteen items. This work conduct to pre-examine and adjust the questionnaire to warrant the content validity. All factors were assessed based on a Likert scale developed by Likert (1932) with five levels, from 1 – totally disagree to 5 - totally agree. The questionnaire was designed in English to ensure the meaning of all measuring items, then converted to Vietnamese to facilitate data collection. Part 1 of the survey asked for respondent information. Part 2 was used to assess three research concepts of the research model.

This study collected empirical data from respondents working in the Danang hospitality industry. Data collection was done through online surveys. The questionnaire was created on Google Docs, and then the questionnaire was shared on Facebook and Google Plus. The questionnaires were distributed over two months, from July 2017 to August 2017. After finishing the process of data collection, 315 valid questionnaires were used for analysis. The information of respondents is shown in Table 1.

Table-1. Information of respondents.

Profile of respondents		Profile of job of respondents	
Items	Percentage (%)	Items	Percentage (%)
<b>Gender</b>		<b>Years of experience</b>	
Male	49.2	Under 1 year	21.3
Female	50.8	2 years – 5 years	35.9
<b>Age</b>		6 years – 9 years	30.5
Under 25 years old	46.3	10 years or more	12.3
26 – 30	34.9	<b>Length of employment at the present business</b>	
31- 35	15.9	Under 1 year	27
36 or Above	2.9	2 years – 5 years	54.3
<b>Marital status</b>		6 years – 9 years	14.5
Single	46.3	10 years or more	4.2
Married	53.7	<b>Number of changes in employer</b>	
<b>Education level</b>		None	4.8
Less than high school	0.9	One	23.8
High school	1.6	Two	47.6
Vocational school	20.6	Three	20
College	14	Four or more	3.8
University	58.7	<b>Job position</b>	
Post-graduate Study	4.2	Standard employees	58.7
<b>Hometown</b>		Supervisory and above	41.3
From Hue City north	65		
From Danang City south	35		

### 3.4. Analysis Techniques

This quantitative study used SPSS 18 and AMOS 21 tools to analyze the collected data. To acquire the respondent's information, we performed the descriptive analysis. Next, we also carried out exploratory factor analysis, reliability test and confirmatory factor analysis. Finally, we used SEM and multi-group analysis to check the hypotheses.

## 4. RESULTS

### 4.1. Exploratory Factor Analysis and Cronbach's Alpha Analysis

Exploratory factor analysis (EFA) was used to extract the dimensions of factors. As shown in Table 2, Using the method of principal component extraction with VARIMAX rotation, three research concepts explained 67.535% of the total variance ( $> 50\%$ ),  $KMO = 0.875 (> 0.5)$  and  $Sig = 0.000 (< 0.05)$ . Thus, three variables were maintained. According to Hair et al. (1998), fifteen observed variables with a factor loading greater than 0.5 were kept, while JP05 with a factor loading less than 0.5 was excluded.

This study carried out a reliability test to check the suitability and reliability of three factors. The results show that Cronbach's alpha values ranged from 0.813 to 0.952. Each measuring item's item-to-total correlations were higher than 0.3. This study confirmed the reliability of basic research when all dimensions had an alpha coefficient higher than 0.7 (Hair, Black, Babin, & Anderson, 1998; Nunnally & Bernstein, 1994).

**Table-2.** Exploratory factor analysis and Cronbach's alpha analysis.

Constructs/ Dimensions	EFA (n=315)			
	Factor loadings	Eigen-values	Explained variance	Cronbach's alpha
Job satisfaction (JS)		5.846	36.536	0.952
JS01- Overall, I am quite satisfied with my job.	0.848			
JS02- I do not intend to work for a different company.	0.927			
JS03- I like my job.	0.879			
JS04- There are no fundamental things I dislike about my job.	0.876			
JS05- I like my job more than many employees of other companies do.	0.908			
JS06- I consider this employer to be my first choice.	0.858			
Job performance (JP)		2.708	16.922	0.867
JP01- I find practical solutions to problems.	0.793			
JP02- I adapt quickly to changing situations.	0.785			
JP03- I assume a sense of ownership and responsibility in the quality of personal performance.	0.770			
JP04- I strive to meet deadlines.	0.779			
JP05- I encourage colleagues to do more than what is expected.	0.374			
JP06- I create effective work relationships with others.	0.800			
Employee Loyalty (EL)		2.252	14.077	0.813
EL01- I am proud to work for this company.	0.776			
EL02- I would recommend this company to family and friends as one of the best places to work.	0.780			
EL03- I would stay with this company even if offered the same job with slightly higher pay at another company.	0.812			
EL04- It is likely for me to work for this company as long as this company wants me.	0.802			
	KMO = 0.875, p = 0.000 Total variance explained = 67.535%			

### 4.2. Confirmatory Factor Analysis

Confirmatory factor analysis (CFA) was used to examine all measurement models. It included convergent validity and discriminant validity. Table 3 shown the criteria of element for measuring the convergent and discriminant validity.



**Table-3.** The criteria for assessing convergent and discriminant validity.

Element	Criteria
Convergent validity (Hair et al., 1998)	
Standardized loadings	> or = 0.7 > 0.5 is acceptable (Bagozzi & Yi, 1988)
SMC	> or = 0.5
CR	> 0.7
AVE	> 0.5
Discriminant validity (Fornell & Larcker, 1981)	
Correlation between two constructs	$r^2 < AVE_1$ and $r^2 < AVE_2$

The results of checking the convergent validity and discriminant validity for measurement models were assessed and reported in Table 4 and Table 5. Compared to the criteria for the assessment Table 3 it was evident that the convergent validity and discriminant validity of measurement models were achieved.

**Table-4.** Results of measurement model evaluation.

Construct	Items	Item reliability			CR	AVE
		Standardized Loading	SMC	t-value		
Job satisfaction (JS)	JS01	0.836	0.699	19.216***	0.952	0.768
	JS02	0.928	0.861	23.444***		
	JS03	0.872	0.761	20.762***		
	JS04	0.865	0.748	20.434***		
	JS05	0.901	0.812	22.088***		
	JS06	0.854	0.729	-		
Employee loyalty (EL)	EL01	0.709	0.503	-	0.813	0.522
	EL02	0.701	0.492	10.541***		
	EL03	0.721	0.520	10.768***		
	EL04	0.757	0.573	11.128***		
Job performance (JP)	JP01	0.776	0.603	-	0.867	0.566
	JP02	0.785	0.616	13.891***		
	JP03	0.745	0.555	13.149***		
	JP04	0.696	0.484	12.189***		
	JP06	0.757	0.573	13.365***		

Note: \*\*\* denotes  $p < 0.001$ .

**Table-5.** Discriminant validity of the measurement model.

AVE/ R <sup>2</sup>	JS	EL	JP
JS	0.768		
EL	0.051	0.522	
JP	0.119	0.069	0.566

#### 4.3. An Assessment of the Structural Model

The theoretical model was examined through the structural equation model (SEM) with three constructs and a correlation matrix among the fifteen measuring items. SEM results depicted in Figure 2 are  $\chi^2 = 223.164$  ( $p = 0.00$ ),  $df = 87$ ,  $\chi^2/df = 2.565$  ( $< 3$ ), CFI = 0.956 & TLI = 0.947 ( $> 0.9$ ) and RMSEA = 0.071 ( $< 0.08$ ). The results indicated that the model fit the data well.

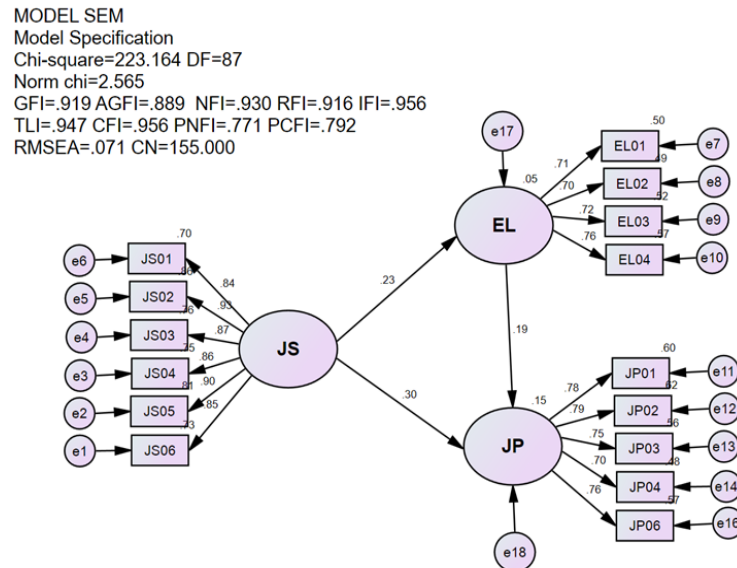

Figure-2. The finalized SEM model.

The path relationships between factors in the proposed model were examined through p-value. Table 6 shows that all paths were significant at  $p < 0.05$ , which means that hypotheses H1 to H3 were accepted. As hypothesized, job satisfaction positively impacts employee loyalty (SEs = 0.226;  $p = 0.000$ ), also confirming previous research (e.g., (Chen et al., 2017; Costen & Salazar, 2011)) and job performance (SEs = 0.302;  $p = 0.000$ ), consistent with other studies (e.g., (Almutairi et al., 2013; Gu & Siu, 2009; Nimalathan & Brabete, 2010; Prasanga & Gamage, 2012; Tsai et al., 2010)). The findings of this work also revealed that employee loyalty has a positive effect on job performance (SEs = 0.194;  $p = 0.004$ ), as seen in previous studies (e.g., (Brown et al., 2011; Chughtai & Zafar, 2006; Darolia et al., 2010; Razzaq et al., 2013)).

Table-6. Results of hypothesis testing.

Hypothesis	Causal path	Standardized estimates (SEs)	Standard error	CR	p-value	Test results
H1	JS → EL	0.226	0.059	3.512	***	Supported
H2	JS → JP	0.302	0.064	4.843	***	Supported
H3	EL → JP	0.194	0.075	2.915	0.004	Supported

Note: \*\*\* denotes  $p < 0.001$ .

#### 4.4. A Multi-Group Analysis

This study used critical ratios for differences between parameters to evaluate the different impacts among groups of job position (standard employee positions and supervisory positions and above) on the relationships among job satisfaction, employee loyalty and job performance.

The findings from Table 7 show that job position difference does not affect the link between job satisfaction and job performance, nor employee loyalty and job performance ( $p > 0.1$ ). Job satisfaction does not have a significant effect on employee loyalty for positions at the supervisory level and above (Estimate = 0.063 &  $p = 0.494$ ); there is, however, a direct influence for the standard employee position group (Estimate = 0.329 &  $p = 0.000$ ). As a result, the impacts of job satisfaction on employee loyalty differ between standard employee positions and positions at the supervisory level and above ( $p < 0.1$ ). The effect of job satisfaction on employee loyalty is stronger for standard employee positions than for positions at the supervisory level and above.

Table-7. Results of a multi-group analysis.

Hypothesis				Standard employee positions		Positions at the supervisory level and above		z-stat	Result
				Estimate	P	Estimate	P		
H4a	JS	→	EL	0.329	0.000	0.063	0.494	-2.187**	Supported
H4b	JS	→	JP	0.398	0.000	0.215	0.023	-1.407	Unsupported
H4c	EL	→	JP	0.246	0.014	0.137	0.221	-0.724	Unsupported

Notes: \*\*\* p-value < 0.01; \*\* p-value < 0.05; \* p-value < 0.10.

## 5. CONCLUSION

Employees are an important tool and vital for the success of every enterprise; as such, the behavior of employees has been the most intensely researched topic in this field. The hospitality industry in Danang has actively contributed to the development of Danang tourism sector. In the success of accommodation businesses, the human is considered as a vital factor contributing to create a difference for the organization. Lodging managers, therefore, have paid much attention to the characteristics of individual employee behavior, particularly job satisfaction, employee loyalty and job performance. This study aimed at comprehending the nature of the relationships between job satisfaction, employee loyalty and job performance among Danang hospitality workers. This empirical study surveyed 315 respondents who have been worked in various lodging businesses in Danang. This work applied structural equation modeling (SEM) and a multi-group analysis to test hypotheses. Empirical results confirmed that the model fit the data well. This study provides important implications for lodging businesses through theoretical and practical contributions.

### 5.1. Managerial Implications

The research results confirmed that job satisfaction positively effect on employee loyalty (0.226) and job performance (0.302), as well as demonstrating that employee loyalty positively affects job performance (0.194). These results emphasized the importance of job satisfaction in building up loyalty and job performance of employees in the hospitality industry. In short, it can be said that a satisfied worker can also be loyal to his organization: the more effectively employees work, the higher their loyalty towards the firm. Employees feel satisfied with their work when their expectations (e.g., working environment, working relationships, promotion opportunities, salary policy and so on) are met. Meanwhile, employee loyalty and job performance are the outcome of job satisfaction.

Therefore, lodging businesses are always looking for elements that influence the job satisfaction of employees, causing employees to adjust and develop issues related to job satisfaction. For example, Danang lodging businesses should provide more competitive salaries than competitors and create more advancement opportunities for employers to not only entice many workers but also retain them. In addition, to bring high job satisfaction to workers, the enterprises can organize more team-building activities to build close relationships between superiors and subordinates and among colleagues, such as traveling together or organizing events for special occasions. Finally, companies should create more rewarding programs, give promotions when warranted, and offer salary augmentation to increase job satisfaction.

The results from this work confirmed that the effect of job satisfaction on employee loyalty is higher for standard employee positions than for positions at the supervisory level and above. It can be explained that workers in supervisory positions and above often have a lot of experience, therefore they can complete their work independently and are less contingent upon other individuals. In addition, although their level of job satisfaction could be low, they felt unsure about quitting after considering their job status plus salary and remuneration.

In contrast, workers in standard employee positions are often young people; perhaps they have just recently graduated or have less work experience, and as such will pay more attention to their working environment,

working relationships, and the factors satisfying them. As a result, if their job satisfaction is high, they will work at the business longer to build up their work experience; however, if they are not satisfied, their readiness to quit the job will be higher. From the above discussion, it is necessary for lodging managers to deeply understand what elements bring satisfaction to each job position group to enhance their job satisfaction, thereby increasing their loyalty.

### 5.2. Future Research

This study makes some implications about the Danang hospitality industry by evaluating the relationships among job satisfaction, employee loyalty and job performance. However, this study was not fully highly representative for the hospitality industry in other cities because the collected sample was quite small. Therefore, further study needs to be conducted with a larger sample to get more generalized findings, and the effects of more moderating variables should be investigated to ascertain how different groups perceive job satisfaction, employee loyalty and job performance.

**Funding:** This study received no specific financial support.

**Competing Interests:** The authors declare that they have no competing interests.

**Acknowledgement:** All authors contributed equally to the conception and design of the study.

## REFERENCES

- Abdullah, R. B., Karim, N. B. A., Patah, M. O. R. B. A., Zahari, H., Nair, G. K. S., & Jusoff, K. (2009). The linkage of employee satisfaction and loyalty in hotel industry in Klang Valley, Malaysia. *International Journal of Business and Management*, 4(10), 152-160. Available at: <https://doi.org/10.5539/ijbm.v4n10p152>.
- Aguinis, H. (2009). *Performance management* (2nd ed.). Upper Saddle River, NJ: Pearson Education Inc.
- Alexander, J. A., Lichtenstein, R., Oh, H. J., & Ullman, E. (1998). A causal model of voluntary turnover among nursing personnel in long-term psychiatric settings. *Research in Nursing & Health*, 21(5), 415-427. Available at: [https://doi.org/10.1002/\(sici\)1098-240x\(199810\)21:5<415::aid-nur5>3.0.co;2-q](https://doi.org/10.1002/(sici)1098-240x(199810)21:5<415::aid-nur5>3.0.co;2-q).
- Ali, W. (2016). Understanding the concept of job satisfaction, measurements, theories and its significance in the recent organizational environment: A theoretical framework. *Archives of Business Research*, 4(1), 100-111. Available at: <https://doi.org/10.14738/abr.41.1735>.
- Allen, N. J., & Grisaffé, D. B. (2001). Employee commitment to the organization and customer reactions: Mapping the linkages. *Human Resource Management Review*, 11(3), 209-236. Available at: [https://doi.org/10.1016/s1053-4822\(00\)00049-8](https://doi.org/10.1016/s1053-4822(00)00049-8).
- Allen, M. J., & Yen, W. M. (1979). *Introduction to measurement theory*. Monterey, CA: Brooks-Cole.
- Almutairi, D. O., Moradi, E., Idrus, D., Emami, R., & Alanazi, T. R. (2013). Job satisfaction and job performance: A case study of five-star hotels in Riyadh, Saudi Arabia. *World*, 3(1), 27-37.
- Angle, H. L., & Perry, J. L. (1981). Organizational commitment and organizational effectiveness: An empirical assessment. *Administrative Science Quarterly*, 26(1), 1-14. Available at: <https://doi.org/10.2307/2392596>.
- Anne, M., & Grønholdt, L. (2001). Using employee satisfaction measurement to improve people management: An adaptation of Kano's quality types. *Total Quality Management*, 12(7-8), 949-957. Available at: <https://doi.org/10.1080/09544120120096098>.
- Armstrong, M. (2006). *A handbook of human resource management practice* (10th ed.). London: Kogan Page.
- Arsić, M., Nikolić, D., Zivković, Z., Urošević, S., & Mihajlović, I. (2012). The effect of TQM on employee loyalty in transition economy, Serbia. *Total Quality Management & Business Excellence*, 23(5-6), 719-729. Available at: <https://doi.org/10.1080/14783363.2012.669930>.
- Aziri, B. (2011). Job satisfaction, a literature review. *Management Research and Practice*, 3(4), 77-86.
- Bagozzi, R. P., & Yi, Y. (1988). On the evaluation of structural equation models. *Journal of Academy of Marketing Science*, 16(1), 74-94. Available at: <https://doi.org/10.1177/009207038801600107>.

- Bettencourt, L. A., Gwinner, K. P., & Meuter, M. L. (2001). A comparison of attitude, personality, and knowledge predictors of service-oriented organizational citizenship behaviors. *Journal of Applied Psychology, 86*(1), 29-41. Available at: <https://doi.org/10.1037//0021-9010.86.1.29>.
- Brown, S., McHardy, J., McNabb, R., & Taylor, K. (2011). Workplace performance, worker commitment, and loyalty. *Journal of Economics & Management Strategy, 20*(3), 925-955. Available at: <https://doi.org/10.1111/j.1530-9134.2011.00306.x>.
- Chaturvedi, V. (2010). A study on factors affecting job satisfaction of employees in hotel industry: A study with reference to few categorized hotels in NCR. *Management Prudence, 1*(2), 40-51.
- Chen, Y. C., Tsui, P. L., & Lee, C. S. (2017). The effect of international hotel employee loyalty on customer behavioral intention in Taiwan. *International Journal of Managerial Studies and Research, 5*(2), 76-81. Available at: <https://doi.org/10.20431/2349-0349.0502008>.
- Chughtai, A. A., & Zafar, S. (2006). Antecedents and consequences of organizational commitment among Pakistani university teachers. *Applied HRM Research, 11*(1), 39-64.
- Costen, W. M., & Salazar, J. (2011). The impact of training and development on employee job satisfaction, loyalty, and intent to stay in the lodging industry. *Journal of Human Resources in Hospitality & Tourism, 10*(3), 273-284. Available at: <https://doi.org/10.1080/15332845.2011.555734>.
- Danang Department of Tourism. (2018). The signing ceremony of cooperation between Empire Group and Da Nang Universities about human resources development. Retrieved from: <http://tourism.danang.gov.vn/home>. [Accessed March, 2018].
- Darolia, C., Kumari, P., & Darolia, S. (2010). Perceived organizational support, work motivation, and organizational commitment as determinants of job performance. *Journal of the Indian Academy of Applied Psychology, 36*(1), 69-78.
- Dugguh, S. I., & Dennis, A. (2014). Job satisfaction theories: Traceability to employee performance in organizations. *IOSR Journal of Business and Management, 16*(5), 11-18. Available at: <https://doi.org/10.9790/487x-16511118>.
- Elegido, J. M. (2013). Does it make sense to be a loyal employee? *Journal of Business Ethics, 116*(3), 495-511. Available at: <https://doi.org/10.1007/s10551-012-1482-4>.
- Eskildsen, J. K., & Nussler, M. L. (2000). The managerial drivers of employee satisfaction and loyalty. *Total Quality Management, 11*(4-6), 581-588. Available at: <https://doi.org/10.1080/09544120050007913>.
- Fisher, C. D. (2003). Why do lay people believe that satisfaction and performance are correlated? Possible sources of a commonsense theory. *Journal of Organizational Behavior: The International Journal of Industrial, Occupational and Organizational Psychology and Behavior, 24*(6), 753-777. Available at: <https://doi.org/10.1002/job.219>.
- Fornell, C., & Larcker, D. F. (1981). Evaluating structural equation models with unobservable variables and measurement error. *Journal of Marketing Research, 18*(1), 39-50. Available at: <https://doi.org/10.2307/3151335>.
- Fosam, E., Grimsley, M., & Wisher, S. (1998). Exploring models for employee satisfaction with particular reference to a police force. *Total Quality Management, 9*(2-3), 235-247. Available at: <https://doi.org/10.1080/0954412989090>.
- Fu, W., & Deshpande, S. P. (2014). The impact of caring climate, job satisfaction, and organizational commitment on job performance of employees in a China's insurance company. *Journal of Business Ethics, 124*(2), 339-349. Available at: <https://doi.org/10.1007/s10551-013-1876-y>.
- Gazioglu, S., & Tansel, A. (2006). Job satisfaction in Britain: Individual and job related factors. *Applied Economics, 38*(10), 1163-1171. Available at: <https://doi.org/10.1080/00036840500392987>.
- Gu, Z., & Siu, R. C. S. (2009). Drivers of job satisfaction as related to work performance in Macao casino hotels: An investigation based on employee survey. *International Journal of Contemporary Hospitality Management, 21*(5), 561-578. Available at: <https://doi.org/10.1108/09596110910967809>.
- Hair, J. F., Black, W. C., Babin, B. J., & Anderson, R. E. (1998). *Multivariate data analysis* (5th ed.). Upper Saddle River, NJ: Prentice-Hall.
- Hair, J. F., Black, W. C., Babin, B. J., & Anderson, R. E. (2010). *Multivariate data analysis: A global perspective* (7th ed.). Upper Saddle River, NJ: Pearson.

- Hair, J. F., Ringle, C. M., & Sarstedt, M. (2011). PLS-SEM: Indeed a silver bullet. *The Journal of Marketing Theory and Practice*, 19(2), 139-152. Available at: <https://doi.org/10.2753/MTP1069-6679190202>.
- Hershberger, S. L. (2003). The growth of structural equation modeling: 1994-2001. *Structural Equation Modeling*, 10(1), 35-46. Available at: [https://doi.org/10.1207/s15328007sem1001\\_2](https://doi.org/10.1207/s15328007sem1001_2).
- Herzberg, F., Mausne, B., & Snyderman, B. (1959). *The motivation to work* (2nd ed.). Oxford, England: John Wiley.
- Heskett, J., Sasser, J. W. E., & Schlesinger, L. (1997). *The service profit chain: How leading companies link profit and growth to loyalty, satisfaction and value*. New York: Free Press.
- Homburg, C., & Stock, R. M. (2005). Exploring the conditions under which salesperson work satisfaction can lead to customer satisfaction. *Psychology & Marketing*, 22(5), 393-420. Available at: <https://doi.org/10.1002/mar.20065>.
- Hoppock, R. (1935). *Job satisfaction*. New York: Harper and Brothers.
- Hussain, R. I. (2012). The linkage of employee satisfaction and loyalty in hotel industries of Pakistan. *Asian Economic and Financial Review*, 2(8), 1098-1105.
- Javed, M., Balouch, R., & Hassan, F. (2014). Determinants of job satisfaction and its impact on employee performance and turnover intentions. *International Journal of Learning & Development*, 4(2), 120-140. Available at: <https://doi.org/10.5296/ijld.v4i2.6094>.
- Kahya, E. (2009). The effects of job performance on effectiveness. *International Journal of Industrial Ergonomics*, 39(1), 96-104. Available at: <https://doi.org/10.1016/j.ergon.2008.06.006>.
- Lawler, E. E., & Porter, L. W. (1967). The effect of performance on job satisfaction. *Industrial Relations: A Journal of Economy and Society*, 7(1), 20-28. Available at: <https://doi.org/10.1111/j.1468-232X.1967.tb01060.x>.
- Likert, R. (1932). A technique for the measurement of attitudes. *Archives of Psychology*, 140, 1-55.
- Maslow, A. H. (1943). A theory of human motivation. *Psychological Review*, 50(4), 370-396. Available at: <https://doi.org/10.1037/h0054346>.
- Mason, C. M., & Griffin, M. A. (2002). Group task satisfaction: Applying the construct of job satisfaction to groups. *Small Group Research*, 33(3), 271-312. Available at: <https://doi.org/10.1177/10496402033003001>.
- Mathieu, J. E., & Zajac, D. M. (1990). A review and meta-analysis of the antecedents, correlates, and consequences of organizational commitment. *Psychological Bulletin*, 108(2), 171-194. Available at: <https://doi.org/10.1037/0033-2909.108.2.171>.
- Matzler, K., & Renzl, B. (2006). The relationship between interpersonal trust, employee satisfaction, and employee loyalty. *Total Quality Management and Business Excellence*, 17(10), 1261-1271. Available at: <https://doi.org/10.1080/14783360600753653>.
- McNeese-Smith, D. (1996). Increasing employee productivity, job satisfaction, and organizational commitment. *Hospital & Health Services Administration*, 41(2), 160-175.
- Mobley, W. H., Griffeth, R. W., Hand, H. H., & Meglino, B. M. (1979). Review and conceptual analysis of the employee turnover process. *Psychological Bulletin*, 86(3), 493-522. Available at: <https://doi.org/10.1037//0033-2909.86.3.493>.
- Motowidlo, S. J. (2003). *Job performance*. In: Borman, W.C., Ilgen, D. R. & Klimoski, R. J. (Eds.), *Handbook of Psychology: Industrial and Organizational Psychology*. New York: John Wiley.
- Mowday, R. T., Steers, R. M., & Porter, L. W. (1979). The measurement of organizational commitment. *Journal of Vocational Behavior*, 14(2), 224-247. Available at: [https://doi.org/10.1016/0001-8791\(79\)90072-1](https://doi.org/10.1016/0001-8791(79)90072-1).
- Muindi, F., & K'Obonyo, P. (2015). Quality of work life, personality, job satisfaction, competence, and job performance: A critical review of literature. *European Scientific Journal*, 11(6), 223-240.
- Nabi, M. N., Syduzzaman, M., & Munir, M. S. (2016). The impact of human resource management practices on job performances: A case study of Dhaka Bank Pvt. Ltd., Bangladesh. *Human Resource Management Research*, 6(2), 45-54.
- Nguyen, T. N. (2016). Training to improve the quality of human resources in the field of tourism. *Financial Magazine*, 6, 93-94.
- Nimalathasan, B., & Brabete, V. (2010). Job satisfaction and employees' work performance: A case study of people's bank in Jaffna Peninsula, Sri Lanka. *Management and Marketing Journal*, 8(1), 43-47.



- Nunnally, J. C. (1978). *Psychometric theory*. New York: McGraw-Hill Inc.
- Nunnally, J. C., & Bernstein, I. H. (1994). *Psychometric theory* (3rd ed.). New York: McGraw-Hill.
- Prasanga, A. A., & Gamage, A. S. (2012). Job satisfaction and job performance of the sailors in rapid action boat Squadron of Sri Lanka Navy. *Sri Lankan Journal of Human Resource Management*, 3(1), 49-57. Available at: <https://doi.org/10.4038/sljhrm.v3i1.5097>.
- Pushpakumari, M. D. (2008). The impact of job satisfaction on job performance: An empirical analysis. *In City Forum*, 9(1), 89-105.
- Razzaq, A., Ayub, A., Arzu, F., & Aslam, M. S. (2013). The nexus between technological learning, downsizing, employee commitment, and organizational performance. *Business Management Dynamics*, 2(10), 74-80.
- Ricketta, M. (2002). Attitudinal organizational commitment and job performance: A meta-analysis. *Journal of Organizational Behavior*, 23(3), 257-266. Available at: <https://doi.org/10.1002/job.141>.
- Santa, C. F. G., López-Guzmán, T., & Cañizares, S. M. S. (2014). Analysis of job satisfaction in the hotel industry: A study of hotels in Spain. *Journal of Human Resources in Hospitality & Tourism*, 13(1), 63-80. Available at: <https://doi.org/10.1080/15332845.2013.807394>.
- Sonntag, S., & Frese, M. (2002). Performance concepts and performance theory. *Psychological Management of Individual Performance*, 23(1), 3-25. Available at: <https://doi.org/10.1002/0470013419.ch1>.
- Syptak, J. M., Marsland, D. W., & Ulmer, D. (1999). Job satisfaction: Putting theory into practice. *Family Practice Management*, 6(9), 26-30.
- The World Travel & Tourism Council. (2018). The economic impact of travel & tourism. Retrieved from: <https://www.wttc.org/-/media/files/reports/economic-impact-research/cities-2018/city-travel-tourism-impact-2018final.pdf>. [Accessed January, 2019].
- Tran, T. V., Vo, T. Q. N., Cao, T. D., & Doan, T. H. T. (2015). Customer-based brand equity and its application to destination: A case of domestic tourists in Danang City, Vietnam. *Australian Journal of Basic and Applied Sciences*, 9(23), 275-281.
- Tran, T. K. P., & Tran, T. V. (2017). An empirical study on factors effecting the job satisfaction of employees in the hospitality industry - A case of Danang city, Vietnam. *Asian Journal of Empirical Research*, 7(7), 160-175. Available at: <https://doi.org/10.18488/journal.1007/2017.7.7/1007.7.160.175>.
- Tran, T. V., Nga, V. T. Q., & Nguyen, N. P. (2017). The causal relationships between components of customer-based brand equity for a destination: Evidence from South Korean tourists in Danang city, Vietnam. *Asian Economic and Financial Review*, 7(4), 358-367. Available at: <https://doi.org/10.18488/journal.aefr/2017.7.4/102.4.358.367>.
- Tran, T. V., & Tran, T. K. P. (2017). Examining the interrelationships among destination brand image, destination perceived quality, tourist satisfaction and tourist loyalty: evidence from Danang city, Vietnam. *International Journal of Tourism Policy*, 7(4), 352-374. Available at: <https://doi.org/10.1504/IJTP.2017.088299>.
- Truc, D. (2017). Danang suffers from the tourism industry's thirst. Retrieved from: <http://www.baomoi.com/da-nang-dau-dau-voi-con-khat-nhan-luc-nganh-dulich/c/22234016.epi>. [Accessed March, 2016].
- Tsai, M.-C., Cheng, C.-C., & Chang, Y.-Y. (2010). Drivers of hospitality industry employees' job satisfaction, organizational commitment and job performance. *African Journal of Business Management*, 4(18), 4118-4134.
- Vietnam National Administration of Tourism. (2018a). Total revenue from tourists during 2000 - 2018. Retrieved from: <http://vietnamtourism.gov.vn/index.php/items/13462>. [Accessed October, 2018].
- Vietnam National Administration of Tourism. (2018b). Vietnam ranks 3rd in the top 10 countries with the fastest international tourist growth. Retrieved from: <http://vietnamtourism.gov.vn/index.php/items/27298>. [Accessed October, 2018].
- Volkwein, J. F., & Parmley, K. (2000). Comparing administrative satisfaction in public and private universities. *Research in Higher Education*, 41(1), 95-116. Available at: <https://doi.org/10.1023/A:1007094429878>.
- Vroom, V. H. (1964). *Work and motivation*. New York: John Wiley and Sons.
- Wang, T., Tran, T. K. P., & Tran, T. V. (2017). Destination perceived quality, tourist satisfaction and word-of-mouth. *Tourism Review*, 72(4), 392-410. Available at: <https://doi.org/10.1108/TR-06-2017-0103>.

- Waqas, A., Bashir, U., Sattar, M. F., Abdullah, H. M., Hussain, I., Anjum, W., & Arshad, R. (2014). Factors influencing job satisfaction and its impact on job loyalty. *International Journal of Learning and Development*, 4(2), 141-161. Available at: <https://doi.org/10.5296/ijld.v4i2.6095>.
- Wright, T. A. (2006). The emergence of job satisfaction in organizational behavior: A historical overview of the dawn of job attitude research. *Journal of Management History*, 12(3), 262-277. Available at: <https://doi.org/10.1108/17511340610670179>.
- Wright, T. A., Cropanzano, R., & Bonett, D. G. (2007). The moderating role of employee positive well being on the relation between job satisfaction and job performance. *Journal of Occupational Health Psychology*, 12(2), 93-104. Available at: <https://doi.org/10.1037/1076-8998.12.2.93>.
- Yin, C. S., Fen, C. Y., Meng, K. Y., Yin, L. P., & Jack, W. W. (2012). *A study of employee satisfaction and its effects toward loyalty in hotel industry*. Bachelor Thesis of Business Administration.
- Yvonne, W., Rahman, R. H. A., & Long, C. S. (2014). Employee job satisfaction and job performance: a case study in a franchised retail-chain organization. *Research Journal of Applied Sciences, Engineering and Technology*, 8(17), 1875-1883. Available at: <https://doi.org/10.19026/rjaset.8.1176>.

*Views and opinions expressed in this article are the views and opinions of the author(s), Asian Economic and Financial Review shall not be responsible or answerable for any loss, damage or liability etc. caused in relation to/arising out of the use of the content.*