





AN INVESTIGATION OF AIR CONSUMPTION OF AIR-JET LOOM



 **Mohammad Mobarak Hossain¹⁺**

 **Habiba Alaya Suchona²**

 **Mst. Tanzina Nasrin³**

 **Imran Hossain⁴**

^{1,2,3,4}Department of Textile Engineering, Bangladesh University of Business and Technology (BUBT), Mirpur, Dhaka, Bangladesh.

¹Email: mobaraknits89@gmail.com Tel: +8801831521093

²Email: habibaalaya18@gmail.com Tel: +8801841297248

³Email: tanzinanasrin39@gmail.com Tel: +8801621729039

⁴Email: imranbd555@gmail.com Tel: +8801770123449



(+ Corresponding author)

ABSTRACT

Article History

Received: 23 October 2020

Revised: 17 November 2020

Accepted: 15 December 2020

Published: 5 January 2021

Keywords

Air-jet weaving

Air compressor

Compressed air

Main nozzle

Sub nozzles

Production

Efficiency.

Output is the key factor for the textile industry to keep pace with the present competitive environment, prompting researchers and machine producers to spend millions of dollars to ensure modern advances in method and equipment. The air-jet loom is now the only machine in the weaving industry that provides the highest efficiency of almost all types of yarn at a higher speed than other current looms without any problem. The production costs in the air jet loom are high due to the use of compressed air and electricity, making it less preferable in some cases of simple weave construction production. This study discusses the reasons for high air consumption and ways of minimizing it in the air jet loom. The factors leading to higher air consumption in the air jet loom and ways of reducing it have been investigated. Via various models of the air-jet loom, we investigated the variables that contribute to high air consumption.

Contribution/ Originality: This study in one of very few studies which have investigated the difference in air-consumption of air-jet weaving machine of different models using in the industries for production.

1. INTRODUCTION

Air-jet weaving is the most common of all weaving machines available today due to its new characteristics, efficacy, and high production performance success than others in the textile industry [1]. Weft air insertion was first introduced in 1914. The aim of creation after that was nozzle forms (main, suction, sub or relay), confuser drop wires, reed types (tunnel, profile, confuser) [2-5]. Research is being carried out on regulating and reducing air intake to increase the weft insertion speed with greater performance. Via the careful regulation of filtered and compressed high air pressure, these systems aid to insert the weft wool. In air-jet weaving, the use of compressed air and the extra expense of compressor power, processing and repair costs are heavy. Air-jet weaving is thus preferred where energy expense, considering its fast production pace, is the concern [6]. So energy conservation is the most critical of today's air-jet loom-related technological topics. Research into the enhancement of main nozzles, sub nozzles, and some other parameters of the loom that play an important role in weft insertion will minimize the consumption of air. In addition to certain other effective air compressor parameters, compressed air output quality may also be increased to decrease energy costs [7, 8]. Reducing energy usage by a compressed air device has been seen as a difficult activity owing to technological barriers. Intensive attempts have been made by researchers and air-jet loom manufacturers to address this issue and achieve a drastic reduction in air usage without decreasing

loom efficiency and fabric quality [9, 10]. From the previous edition of air-jet looms, Toyota, Tsudakoma, Picanol, Dornier, RIFA, ITEMA have spent a lot in continuous production. Thus, after the marketing of the first commercial air-jet loom introduced in the 20th century, with the help of companies from Swiss, Dutch, Japanese, USA, etc., the researcher never stopped to boost the efficiency of this product throughout the century. In order to render tire cords for automobile and aircraft tires with simple operation and minimum service specifications with optimum efficiency and fabric consistency, Dornier invented air-jet weaving. It also promises to save time and resources in the process, achieving low cost and high benefit [11]. Item a created an air-jet weaving system specially built by their brand-new designers to weave intricate fabrics with different fibers, including linen, cotton, silk, synthetics, and blends, providing a fast, cold, and relaxed feeling against the skin. They also assert that with continuous air load regulation and strain, they decrease energy usage. Their new software patent, shed geometry, heald frame architecture, reed tunnel shape, and relay nozzle location to maximize airflow achieve high efficiency in the insertion of weft [12]. For the 1st pick timing with loom RPM variance, Tsudakoma has created new air-jet weaving models that save energy, strength, labor, and no changes. Therefore, the decrease in air usage was important relative to their traditional model [13]. Toyota Industrial Corporation has since made some enhancements to the JAT series design concept. In their latest equipment, Air-Saving System, E-shed or electronic shedding motion, new feature panel and a factory management system are added to reduce air usage [14]. In high performance systems, PIC (Permanent Insertion Control) and AWC (Active Weft Control) are also successful [15]. Practical applications in weaving mills are critical for researchers and machine manufacturers to work hard after the invention of the air-jet picking mechanism to minimize air consumption [16]. The key goal of research is the cost-efficient air-jet loom. Emphasized onset of irregular activity, such as the kinetic energy from air pressure through a tube, propulsive force and the relationship with fiber content, linear yarn density and filling velocity, conservation of valve drive time [17-19]. New results are available for more improvements by researching filling injection dynamics, nozzle shape, reed, valves, linear density, yarn structure, twist, velocity with the increase of many filaments, yarn surface contact, yarn forms, compressor [20-24]. Air-index, an indicator of the suitability of weft yarn, helps design multi-hole relay nozzles [25, 26]. Researchers find that sufficient air supply, keeping air-jet in the reed shaft, weft volume, clean shed are technological solutions for insertion of air-jet. Amongst other looms, broad weft insertion, limited air mass, low expense, fast power, low weft dynamic load, simple activity, low noise, and vibration levels held its popularity high. There are numerous updates and recommendations in some publications written lately [15]. Air-jet weaving devices will now weave virtually all sorts of yarns at faster speeds than the projectile and rapier devices without any issues. An excellent solution to other weft entry devices is Air-jet looms. However, there is also a major downside to this system: heavy power usage due to compressed air generation. Researchers and air-jet loom manufacturers have also made intensive efforts to address this issue and achieve a drastic decrease in air usage without reducing the efficiency of the loom and the consistency of the cloth. However, to accomplish the supposed reductions in air usage, weaving mills' functional implementations are as important as computer designs. By tuning certain loom parameters in a weaving mill, this study aims to substantially reduce air usage.

2. MATERIALS AND METHODS

Our project is about the air consumption and reduction system of the air-jet loom. We need to know how free air is pressurized on a compressor after filtering and air drying to remove dirt and moisture. Here we also need to understand how compressed air is distributed in the weaving loom for air-jet weaving. Here, an investigation of air compressors and air-jet weaving machines with different models reduces energy cost and air consumption.

Air compressor Model

- a) Air cooler GA75
- b) Water cooler ZR355
- c) ELGi air compressor

Air-jet weaving loom Model

- a) TOYOTA JAT600
- b) TOYOTA JAT610

3. DISCUSSION

To make air-jet weaving more cost-effectively, increasing the profit and efficiency with reducing the energy cost. Some parameters which can improve the air-jet weaving system by reducing the cost of air consumption are discussed regarding the version of machines used in the factory-

3.1. Reference Condition Needed for Air Compressor

Compressors used in the industry need a large amount of energy to ensure a continuous supply of purified air into the air jet looms. So, for reducing energy consumption, standard-setting is required to obtain energy efficiency, safety, and reliability. To minimize operational cost following conditions are required-

- a. Compressor property
 - Dry air
 - Absolute inlet pressure 1 bar
 - Cooling and air intake temperature 20
 - Normal working pressure
 - * 7 bar (e) for 7, 7.5 and 8.6 bar variants
 - * 9 bar (e) for 10 and 10.4 bar variants
 - * 12 bar (e) for 13 bar variants
 - Z VSD:5% derating for 380V nets
 - Capacity of the compressor package according to ISO 1217 third Edition.
- b. Cooling water temperature rise of 15°.
- c. Pressure dew point is specified for
 - 20-degree cooling air temperature
 - Relative humidity of 60%
 - Nominal working pressure
 - load level of minimum of 50%
- d. +/-3dB(A) according to ISO 2151:2004 and using ISO1217.
- e. Conversions
 - 1kg =2.2 lbs
 - 1mm = 0.038 inch
- f. Variable speed drive uses for
 - For direct energy saving up to 35%
 - Air intake flexible
 - Unlimited starting and stopping
 - Lower energy consumption
 - Saving on electrical insulation
 - To obtain the best efficiency of motor and convertor

3.2. Types of Compressors with Parameters

Manufacturers of compressors are increasing the compressor's capacity and other features to reduce the cost in the manufacturing plant. There are two types of air compressor with two different components in the Beximco Textile Ltd. These are mentioned below in brief with “Table 1 and 2” with “Figures 1-3”-

Table-1. Air cooler compressor.

Machine name	Atlas copeo
Model	GA75
Brand	ROTATYSC
Origin	India
Capacity	7, 8, 10, 12 bar
Maximum pressure	7.5 bar
Motor power	75 KW, 100Hp
Temperature	110°C
Dimension	Length-2045mm, Width-1250mm, Hight-1705mm
Weight	1820kg
Outlet diameter	G2"
Noise level	68+/-2 dB(A)
Energy supply (v/ ph/ hz)	220V/3p/60Hz, 415V/3p/50Hz, 440V/3p/50Hz, 575v/3p/50Hz
Configuration	Stationary
Ventilation	12.7m3/min
Relative humidity	0%
Air discharge temp	Air cooling<ambient temp(-5to+45°C) +15°C
Transmission efficiency	95%

Table-2. Water cooler compressor.

Machine name	Atlas copeo
Model	ZR 355
Brand	ROTARYSC
Origin	Belgium
Capacity	7.5, 8.6, 10bar
Maximum pressure	8.5 bar
Temperature	>210°C
Motor power	For 7.5 bar 1990KW, For 8.6 bar 1858 KW, For 10 bar 1779 KW, And 355 HP
Dimension	Length-4060mm, Width-2120mm, Hight-2400mm
Maximum speed	1500rpm/ min
Weight	6950kg
Noise level	71-76dB(A)
Free air delivery	For 7.5 bar 949l/s, For8.6 bar 886 l/s, For 10 bar 846 L/s
Cooling water consumption	4.8-4.9l/s
Configuration	Stationary/piston
Ventilation	8.6m3/min for 7 bar, 10.4m3/min for 9 bar
Relative humidity	60%
Air discharge temp	Air cooling<ambient temp(-5to+45°C) +(20 - 30)°C
Transmission efficiency-	60-70%



Figure-1. Air cooler compressor.

Note: Machine name-Atlas copeo GA75
Origin-India
Maximum final pressure-7.5 bar
Free air delivery- 245 l/s (liter per sec)
Motor power- 75kw.



Figure-2. Water cooler compressor.

Note: Machine name- Atlas copeo ZR355
Origin-Belgium
Maximum final pressure- 8.5 bar
Free air delivery- 583 l/s
Motor power - 230kw.



Figure-3. ELGi Air compressor.

3.3. Choosing a More Effective and Efficient Air Compressor

This energy cost and reduction of wastage air will depend not only on the air-jet loom parameters but also on the air compressor's working activity, which contains a large amount of energy cost.

The term air compressor takes a tremendous amount of energy and electricity consumption. So, to reduce cost, we should need to choose a more cost-effective compressor. In the properties of air cooler GA75 and water cooler ZR355, we can see that the air cooler GA75 compressor is more cost-effective than the ZR355 water cooler compressor because of the following reasons,

- Air pressure, power consumption, weight, dimension, noise level: GA75 < ZR compressor.
- GA compressors need a radiator and a separator unit to separate oil and air but in ZR, no need radiator.
- Pressure-bar capacity, ventilation capacity: GA > ZR.
- The transmission efficiency of GA compressor is more significant than ZR.
- Air discharge temperature of GA is lower than ZR so it can easily supply the cooled moisture-free air.
- The relative humidity of ZR is so much greater than GA compressor, so it needs an extra dryer to dry the air's moisture. So that the ZR compressor carries an additional dryer cost.

From the comparison between the air and water cooler, we can see that the air cooler compressor is more effective and efficient than the water cooler compressor. So, if we want to reduce the energy cost, we should need to use the GA compressor. A new model of GA compressor is ELGi, which is also more suitable than GA compressor, and it can be beneficial because of its economically friendly. Besides, using BSD types compressor, energy consumption can be reduced.

3.4. Proper Optimization of Compressed Air

For reducing the air wastages, we should need to optimize the compressed air flow properly. Compressed air cost can be minimized in two ways, which are

a. Preventing Air Leakages

It occurs in a small opening on the pipe, which creates a large amount of air wastage. Following ways to avoid this-

- Use good quality pipes and setting to avoid breaks and leaks.
- Because a 1/16" leak may cost \$523, 6.49 CFM, 1/8" may cost \$2,095, 26 CFM.
- The pipeline should be placed in an un-socking area.
- Properly maintenance of all the pipelines.
- Replace or repair leaky shut-off valve

- Keep the place and the pipe neat and clean.

b. Improving Volumetric Efficiency

The volumetric efficiency of an air compressor has a significant bearing on an air compressor's operational cost. Low volumetric efficiency results in a higher per-unit cost of air. Some main factors for low efficiency are,

- Clogged air inlet filters.
- Obstruction at the inlet valve.
- Hot inlet air.
- Piston ring leakage.
- It is efficiently working with the intercooler and other parameters of the compressor.

3.5. Distribution Lines of Compressed Air with the Layout

The distribution system of air compressors in Beximco Textile Ltd. represents the distribution of compressed air through pipelines. As we know, the distance of compressor and subsequent weaving looms mightily influences air consumption as leakage and the stop and start of loom cause more air consumption during manufacturing. Here, modifying the layout may shorten the distance, and the loom's position should be at the center of the looms in this regard. Primarily this could be set at the beginning of the layout plan of the factory. Here, the existing layout is shown below to observe the current layout plan.

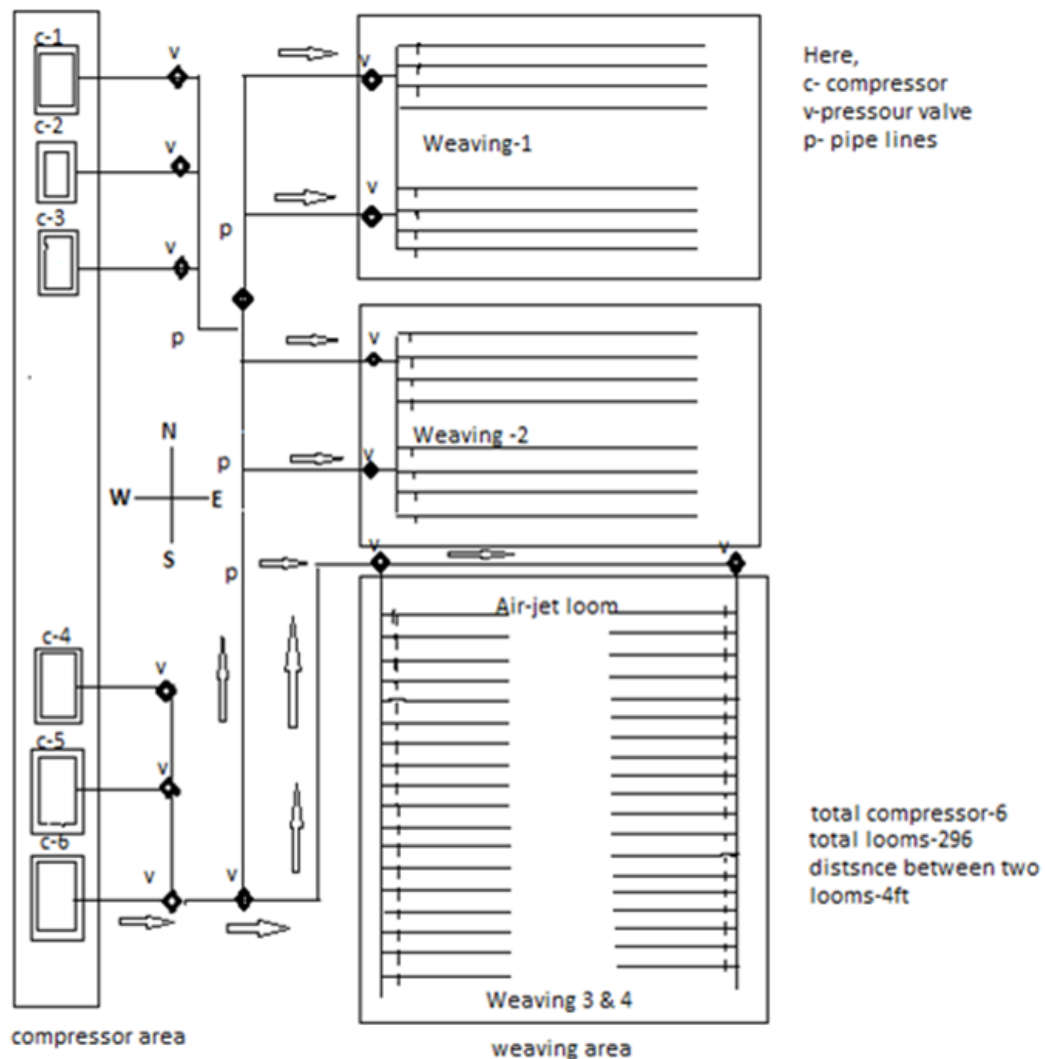

Figure-4. Layout plant in weaving section.

3.6. Properties of Weft Yarn

Properties of weft yarn are fundamental during the time of pick insertion. Factors that vary with yarn's stuff, like for pick insertion in air-jet, it is recommended to use the lightweight yarn to be passed through by the nozzles without any deformation [25].

Table-3. Some properties of weft yarn required in air-jet weaving.

Actual count (Ne)	10-80
Count lea strength product	2516-3995
Twist Multiplier	3.74-4.52
CVm %	9.10-11.9
Thin places -50% /km	0-13
Thick places +50%/ km	27-276
Neps +200%/ km	78-204
Hairiness index	3.07-12.30

Source: Poppe [25]

3.7. Weaving Machine Properties

The reduction of air properties of the weaving machine is also a fundamental term. Some important properties that can improve the machine efficiency and also help in the decrease of air are given below,

- At the time of choosing a machine, modern technology should be followed.
- The machine should run at high speed with low energy consumption.
- Parts of the machine should also be modern and well designed.
- The machine should have sensors and an automatic fault detector.
- Should avoid manual operation in case of any kind of failure.
- High energy needs for heavyweight so machine and machine parts should be of lightweight.
- Keep the machine and area neat and clean.
- Maintenance should be properly done, and air supply pipelines should be adequately checked at regular intervals.
- The well-distributed layout should be followed, and the machine should be kept in a safe and un-socked area.

3.8. Machine Specification



Figure-5. Toyota Air-jet loom.

Note: Machine name- Toyota Air-jet weaving loom
 Origin-Japan
 Brand-TOYOTA
 Model-T600 & T610
 RPM- min600, max 900
 Reed space- 1900mm
 No. of nozzles- 2 nozzles/set (36sets attached staubli dobby)
 Beam dia- 800mm
 Electric valve- 5
 No. of relay nozzles- 25
 No of heald frame- 10-16

3.9. Controlling of Accumulator

In an air-jet weaving machine, so many different parts are used than other ordinary looms. Accumulator and nozzles, for pick insertion, is generally re-stored from the yarn package for proper pick insertion. So it should be appropriately controlled by the following ways to preventing machine fault.

- Yarn guides of the accumulator should be adequately set.
- Speed should properly control until it creates a breakage of yarn.
- Maintain proper tension of the yarn.
- Keep the accumulator clean.

In general, an accumulator or drum feeder can re-store 20-25 turns of yarn according to the pick's length, so pick insertion depends on it. If we can increase the machine speed, then the accumulator's speed will also be high, reducing air consumption. If a sensor or any fault detector is used in an accumulator, it will increase machine efficiency.

3.10. Proper Controlling of the Pressure Regulator

There are use twelve regulators in a weaving loom. Four regulators use for the main nozzle, one for sub nozzle, one for sub end nozzle, etc. The regulator controls the air pressure and helps to pass the air properly. When four EDP work at a time, then they need four main nozzles. But when one EDP works, it does not need four main nozzles; it only requires one main nozzle. These create some wastage; when one EDP works for one main nozzle, the air flows continuously from all regulators. If proper control is done here, we can reduce the wastage of air. Proper controlling of air pressure regulator can save air consumption. If different valves are used for various regulators, then it possible to minimize air wastage.



Figure-6. EDP.

3.11. The Setting of Relay Nozzles

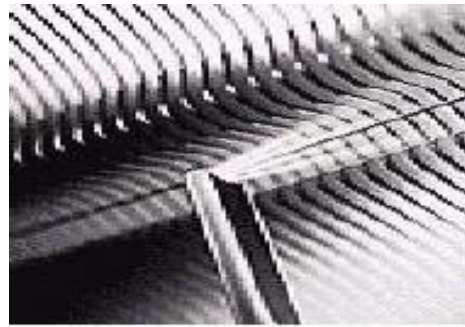

Figure-7. The setting of Relay Nozzles.

3.12. Distance between Two Nozzles

The improper setting between two nozzles will cause variation in air pressure and will decrease machine performance. Here, the air consumption will be unnecessary increase.

3.13. Nozzle Height

Proper height setting of the relay nozzle will reduce air pressure during weft insertion and minimize air consumption. It also provides the uniform displacement of yarn during insertion.

3.14. Nozzle Angle

For uniform weft insertion of yarn during insertion, proper nozzle angle will reduce air consumption.

3.15. Control of Pressure Valve with Relay Nozzles

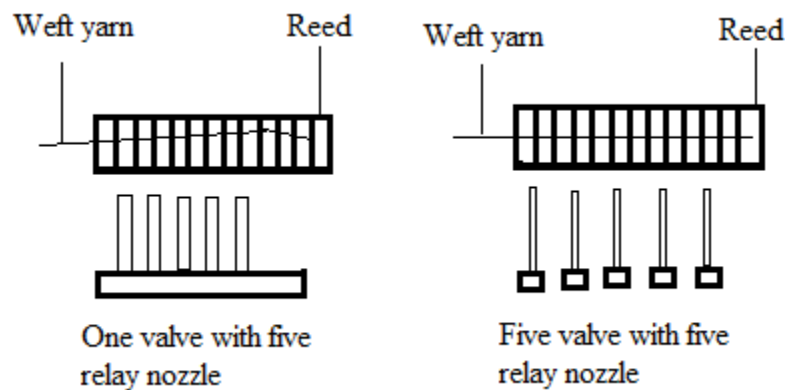

Figure-8. Control of pressure valve with relay nozzles.

Source: Adanur and Turel [19].

In the weaving loom here, one valve is used for five relay nozzle. When one valve is open, it opens with five relay nozzles and the airflow in a long distance. It cannot give proper air in the right place, so wastage is done here. If we can use one valve for one relay nozzle, then it can provide adequate airflow in the right place. In this way, it can save air.

3.16. Effects of Using Single and Multi-Hole Relay Nozzles

A relay nozzle with a single hole is more effective than a double hole nozzle. In a dual-hole nozzle, the air flows abruptly and needs more air to pass the yarn. Air wastage is done here. In a one-hole nozzle, the airflow at the right

angle and the right place. Here needs less air to pass the yarn so it can reduce the wastage of air. But, if the hole's diameter is reduced and the number of holes increased, the manufacturer already suggests using 16 or 19 holes relay nozzles. We could get a stable movement of yarn with less air consumption.

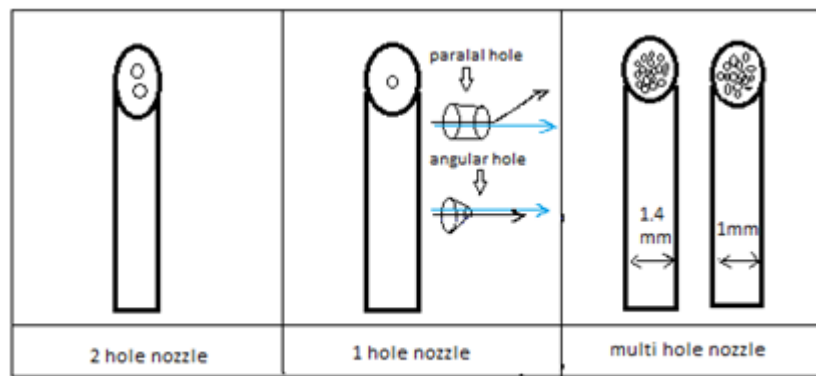

(a)

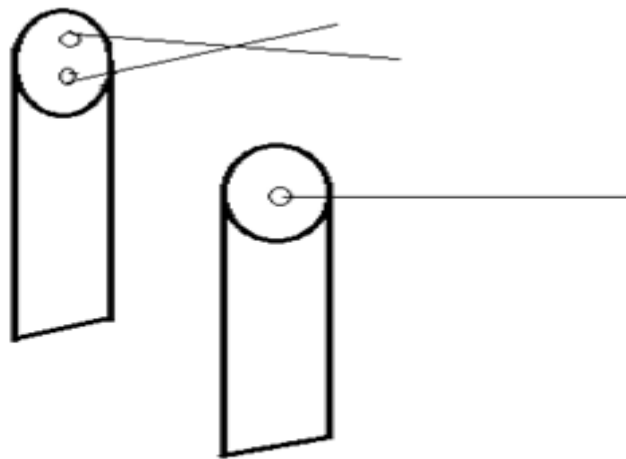

In double hole nozzle air flow here and there but single hole nozzle air flow in right place

(b)

Figure-9. (a) Types of holes in relay nozzles and (b) Effect of holes in relay nozzles. Source: Adanur and Turel [19].

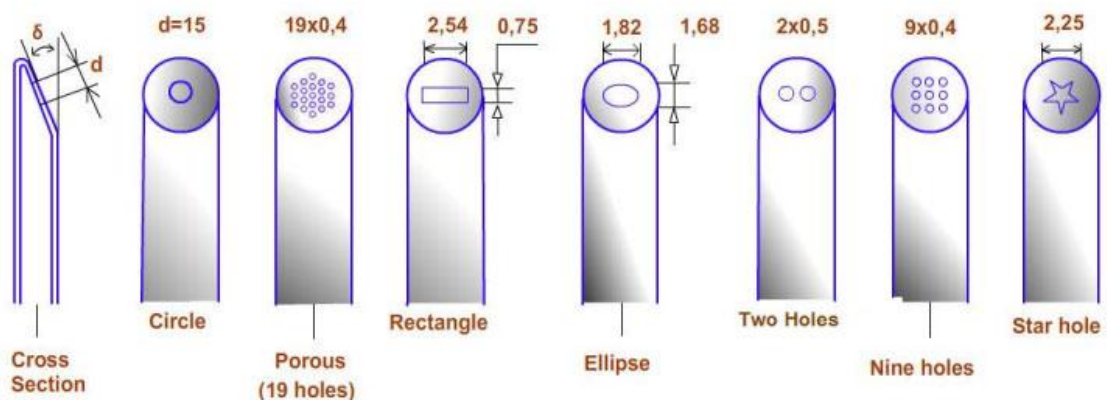

Figure-10. Types of relay nozzles and hole diameter.

Source: Adanur and Turel [19].

3.17. Air consumption by TOYOTA 600 and TOYOTA 610

It is found that yarn properties have great importance during the time of weaving on the air-jet loom. Another essential factor is loom speed, which also varies to get different air consumption values. So here we give a data table of air consumption, where the importance of yarn count and loom speed is different,

Table-4. Comparison of air consumption between TOYOTA 600 and 610 for the different count of weft yarn.

Weft yarn count	Reed width	Speed	Air consumption			Remarks
			TOYOTA 600	TOYOTA 610	Change %	
Cotton Ne 6	175 Cm	625	60	48	20	Nm^3/h
Cotton Ne 10	175 Cm	625	43	34	20.93	Nm^3/h
Cotton Ne 20	175 Cm	625	34	27	20.59	Nm^3/h
Cotton Ne 40	175 Cm	625	29	23	20.69	Nm^3/h
Cotton Ne 60	175 Cm	625	27	21	22.22	Nm^3/h
Cotton Ne 80	175 Cm	625	26	20	23.08	Nm^3/h

Note: Here $1Nm^3/h = 0.588\text{ cfm}$.

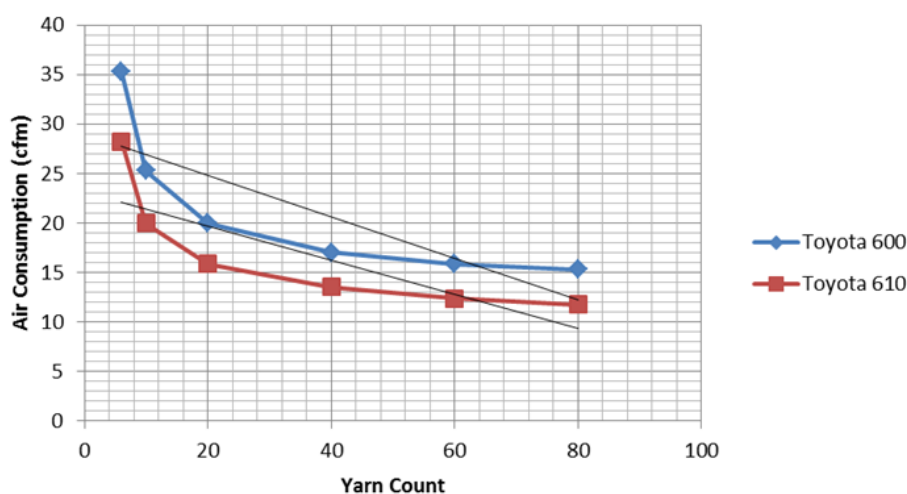

Figure-11. Comparison of air consumption between two models of air-jet loom Toyota 600 and Toyota 610 for the different count of weft yarn.

Table-5. Air consumption of Toyota 610 for the different count at a different speed.

Weft yarn count	Reed width	Air consumption TOYOTA 610			Remarks
		625	900	Change %	
Cotton Ne 10	175 Cm	34	73	53.42	Nm^3/h
Cotton Ne 40	175 Cm	23	43	46.51	Nm^3/h
Cotton Ne 80	175 Cm	20	38	47.36	Nm^3/h

Note: Here $1Nm^3/h = 0.588\text{ cfm}$.

From analyzing different points related to air consumption in the air-jet looms of Toyota 600 and 610 with the layout plan relating with the position of the compressor and passage diagram of the pipeline from compressor section to the weaving section we found, in the model JAT600, we used a nozzle with having two holes. In the model JAT610, we use a 1-hole nozzle. So the compressed air circulation in 1 hole nozzles is greater than the 2-hole nozzle, and it does not need so much pressure as a 2-hole nozzle. For this reason, by using one hole, about 25 % of compressed air will be saved than the other. These compressed air saving percentages should be increased using multi-hole nozzles and angular nozzles where there is an angle in the nozzle mouth. A significant change in air consumption will be observed after replacing different types of relay nozzles like 16-holes, 19-holes, 1-holes, 2-holes, star holed, rectangular holed, etc.

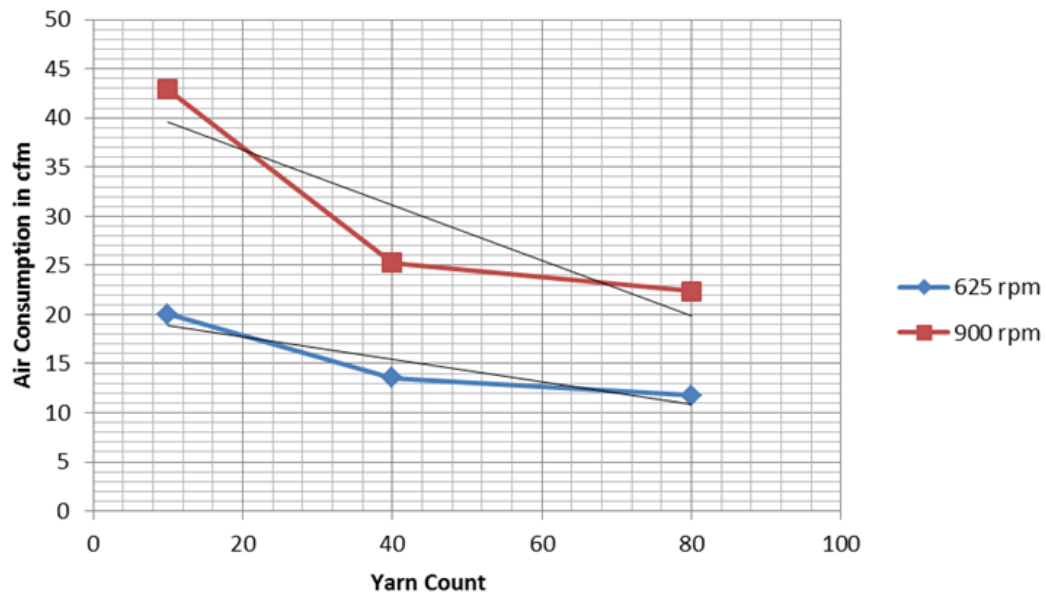

Figure-12. Air consumption by Toyota 610 at 625 rpm and 900 rpm for the different count of weft yarn.

Therefore, weaving mills are recommended to search for the best multi-holed relay nozzles with the manufacturer's help to take the necessary steps in reducing air consumption. Different air compressors are also making an opportunity to choose the best one to meet the low production cost. It is also observed that the loom types can save 20-25% air consumption depending on different models. In some models depending on weft insertion speed, 47-53% air consumption can be saved (if possible, depending on fabric construction).

3.18. Check Points in the Air-jet Loom

1. Compressor and loom surroundings.
 - a. Air leakages in the pipe.
 - b. Bends in pipe.
 - c. Compressor to loom distance.
 - d. Worker practices.
 - e. Vibration of machines.
2. Loom setting.
 - a. Shedding.
 - i. Shedding height.
 - ii. Shed angle.
 - b. Picking.
 - i. Nozzle settings.
 - ii. Opening and closing time.
 - iii. Distance between the nozzles.
 - iv. Number of nozzles.
 - v. Wet insertion rate.
- c. Opening and closing time of different nozzles.
 - i. Main nozzle.
 - ii. Tandem nozzle.
 - iii. Relay nozzle.
 - iv. Stretch nozzle.
3. Loom maintenance.

3.19. Other Changes Required to Reduce Air Consumption

- Relay nozzles with a hole diameter of 1.4 mm replaced with 1.0 mm on the loom.
- Use different holed and angle relay nozzle according to their effectiveness. Like a single holed angular relay nozzle can save air about 20–25% than a parallel holed relay nozzle.
- Bowing time should be optimized with the using types of nozzles.
- Use effective tuck in mechanism because it needs also compressed air for producing selvage.
- Pressure valve controlling during the machine stops and starting or running position properly.
- The distribution pipelines proper setting to reduce the percentages of air leakage.
- Use skilled workers for proper maintenance and performance of weaving loom.

4. CONCLUSION

This study would allow the manufacturer to solve the relevant problems that had been a major problem in the weaving industry about high air intake by air-jet loom. We firmly believe that air consumption will be reduced by a large amount by implementing all these measures, which can save the energy cost of Beximco Textile Ltd. in the Air-jet weaving section consisting of 296 looms. These may save the cost of output, but they would also help boost the industry's sales. This job would also assist producers of machinery, and the industry in Bangladesh has set a price that affects the air-jet weaving segment.

Funding: This study received no specific financial support.

Competing Interests: The authors declare that they have no competing interests.

Acknowledgement: All authors contributed similarly to the study's conception and construction. Thanks to the manufacturing and repair department-related industrial people who helped us accomplish this mission in various parts.

REFERENCES

- [1] M. Kayacan, M. Dayik, O. Colak, and M. Kodalogl, "Velocity control of weft insertion on air jet looms by fuzzy Logic," *Fibres & Textiles in Eastern Europe*, vol. 12, pp. 29-33, 2004.
- [2] J. C. Brooks, "Patent U.S.P," p. 1096283, 1914.
- [3] E. H. Bollou, "Patent U.S.P," p. 1721940, 1929.
- [4] H. Wakefield, "Patent B.P," p. 346307, 1930.
- [5] P. A. B. Maxbo, "Patent B.P," p. 616323, 1945.
- [6] I. Patkó and L. Szabó, "The study of the flow conditions of Air jet weaving machines," presented at the In 10th International Symposium of Hungarian Researchers, Budapest Tech, Nov 12-14, 2009.
- [7] A. Schröter and T. Holtermann, "Increasing energy efficiency of relay nozzles of air jet weaving at the institute of textile technology," presented at the In 14th Chemnitzer Textile Conference, Aachen, 2014.
- [8] J. Githaiga, L. Vangheluwe, and P. Kiekens, "Relationship between the properties of cotton rotor spun yarns and the yarn speed in an air-jet loom," *Journal of Textile Institute*, vol. 91, pp. 35-47, 2000.
- [9] C. Grassi, A. Schröter, Y. Gloy, and T. Gries, "Increasing the energy efficiency of air jet weaving based on a novel method to exploit energy savings potentials in production processes of the textile industry " *Journal of Environmental Science and Engineering*, vol. 5, pp. 26-34, 2016.
- [10] T. Osthus, E. De Weldige, and B. Wulforth, "Reducing set-up times and optimizing processes by the automation of setting procedures on looms," *Mechatronics*, vol. 5, pp. 147-163, 1995.
- [11] P. Dornier, "Dornier, 23 11 2020. Retrieved from: <https://www.lindauerdornier.com/en/weaving-machines/air-jet-weaving-machine-tirecord/>," 2020.
- [12] ITMA, "23 11 2020. Retrieved from: <http://www.itemagroup.com/en/products/airjet/>," 2020.
- [13] Tsudakoma, "23 11 2020. Retrieved from: https://www.tsudakoma.co.jp/english/business/textile/product/air_jet_loom/," 2020.

- [14] T. I. Corporation, "23 11 2020. Retrieved from: <https://www.toyota-industries.com/products/textile/shokki/index.html>," 2020.
- [15] U. N. Haq and M. M. Hossain, "A review on reduction of air consumption in air Jet Loom: The possible setting points," *Journal of Asian Scientific Research*, vol. 7, pp. 52-62, 2017.
- [16] A. Ormerod, "Air jet weft insertion: Present and probable future technical and economic performance," *Journal of the Textile Institute*, vol. 92, pp. 93-108, 2001. Available at: <https://doi.org/10.1080/00405000108659601>.
- [17] S. Adanur and S. Bakhtiyarov, "Analysis of air flow in single nozzle air-jet filling insertion: Corrugated channel model," *Textile Research Journal*, vol. 66, pp. 401-406, 1996. Available at: <https://doi.org/10.1177/004051759606600608>.
- [18] S. Adanur and M. H. Mohamed, "Analysis of yarn motion in single-nozzle air—jet filling insertion: Part I," *Theoretical Models for Yarn Motion, The Journal of Textile Institute*, vol. 83, pp. 45-55, 1992.
- [19] S. Adanur and T. Turel, "Effects of air and yarn characteristics in air-jet filling insertion: Part II: Yarn velocity measurements with a profiled reed," *Textile Research Journal*, vol. 74, pp. 657-661, 2004.
- [20] S. A. Tarabdkar, H. M. Sharma, and D. H. Yadav, "Assessment of compressed air requirement for spinning and weaving machines," *BTRA Scan*, vol. 31, pp. 15-21, 2001.
- [21] M. Ishida and A. Okajima, "Flow characteristics of the main nozzle in an air-jet loom: part I: Measuring flow in the main nozzle," *Textile Research Journal*, vol. 64, pp. 10-20, 1994.
- [22] M. Ishida and A. Okajima, "Flow characteristics of the main nozzle in an air-jet loom part ii: Measuring high speed jet flows from the main nozzle and weft drag forces," *Textile Research Journal*, vol. 64, pp. 88-100, 1994.
- [23] S. Y. Jeong, K. H. Kim, J. H. Choi, and C. K. Lee, "Design of the main nozzle with different acceleration tube and diameter in an air-jet loom," *International Journal of Precision Engineering and Manufacturing*, vol. 6, pp. 23-30, 2005.
- [24] M. Mohamed and M. Salama, "Mechanics of a single nozzle air-jet filling insertion system part i: Nozzle design and performance," *Textile Research Journal*, vol. 56, pp. 683-690, 1986.
- [25] T. Poppe, "The influence of rotor yarn properties on air consumption in air jet weaving," Master's Thesis, Institute of Textile and Process Technology, University of Stuttgart, 1995.
- [26] N. V. Picanol, *The air index, a new reference for yarn evaluation*: Picanol News, 2001.

Views and opinions expressed in this article are the views and opinions of the author(s), Journal of Asian Scientific Research shall not be responsible or answerable for any loss, damage or liability etc. caused in relation to/arising out of the use of the content.